

MAGIC 23

PREMIUM TOOLS / QUALITY MADE BY GEDORE



€108,40
+ VAT

**Bit-Set 1/4"
FLEX**
38 pieces

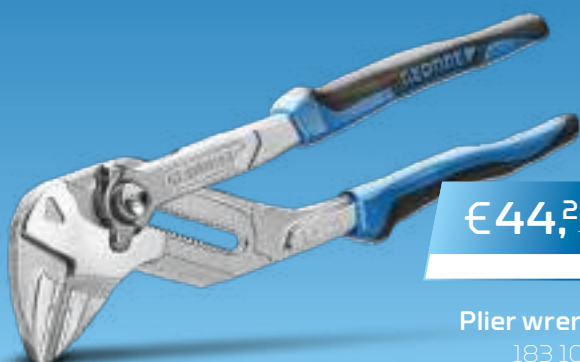

€44,28
+ VAT

Plier wrench
183 10 JC



€1310,08
+ VAT

Workshop trolley
2005 XL 0330

VDE 183 10
VDE-PLIER WRENCH

110

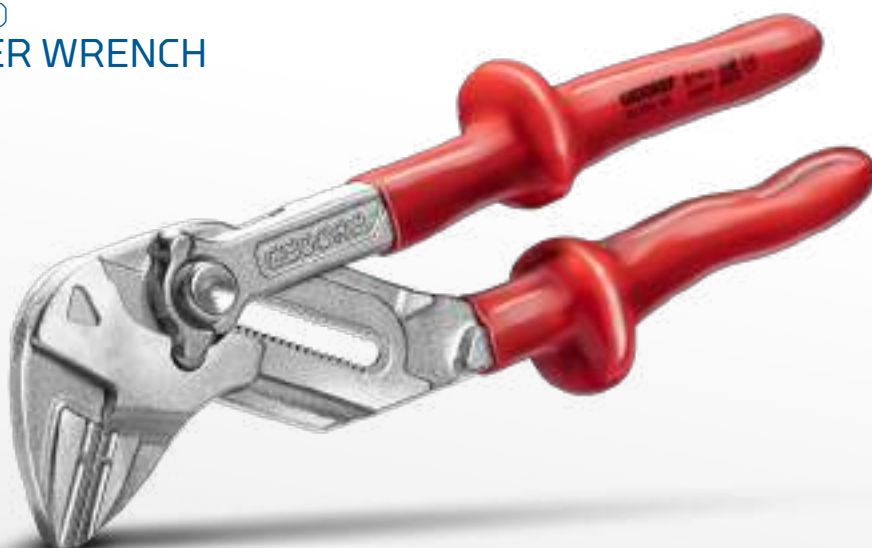

1504 XL-S-198 AGRAR
WORKBENCH
WITH BASIC SET

124



HIGHLIGHTS
2023





CONTENTS

















1102-038
BIT-SET 1/4"
FLEX

8



TF-K
TORQUE
WRENCH
TORCOFIX TF-K

26

	SPANNERS	04 – 07
	SOCKETS AND ACCESSORIES	08 – 25
	TORQUE TOOLS	25 – 35
	SCREWDRIVERS	36 – 38
	WORKSHOP EQUIPMENT	39 – 59
	TOOL ASSORTMENTS	60 – 62
	MODULE	63 – 75
	MOBILE TOOL STORAGE	76 – 80
	PULLERS	81 – 90
	HAMMERS / STRIKING TOOLS	91 – 93
	PLIERS	94 – 99
	WORKSHOP SUPPLIES	100-104, 127-129
	VDE INSULATED SAFETY TOOLS	105 – 113
	AUTOMOTIVE	114 – 121
	AGRI	122 – 126
	OCHSENKOPF	130 – 131

OPEN-END SPANNERS WITH RING RATCHET IN A SET - 8 TO 19 MM

Whether in industrial use, in trade or when tightening bolts on the vehicle - with the combination ratchet wrench from **GEDORE** you have a precise and reliable tool for the most common screw connections.

The **GEDORE 7 R-012 combination ratchet wrench set** contains 12 ratchet wrenches in a robust steel case in various sizes. From wrench size 8 to 19 mm, the set contains the right tool for different areas of application. The torsion-resistant construction of the wrenches ensures maximum torque transmission. The Unit Drive Profile ensures a secure connection between the combination ratchet wrench and the screw or bolt. The even power transmission via the wave-shaped profile ensures an even distribution of pressure even under the highest loads - the screw is prevented

from turning and being damaged. With an additional adapter, the ring ratchet wrench becomes a ratchet with a low installation height.

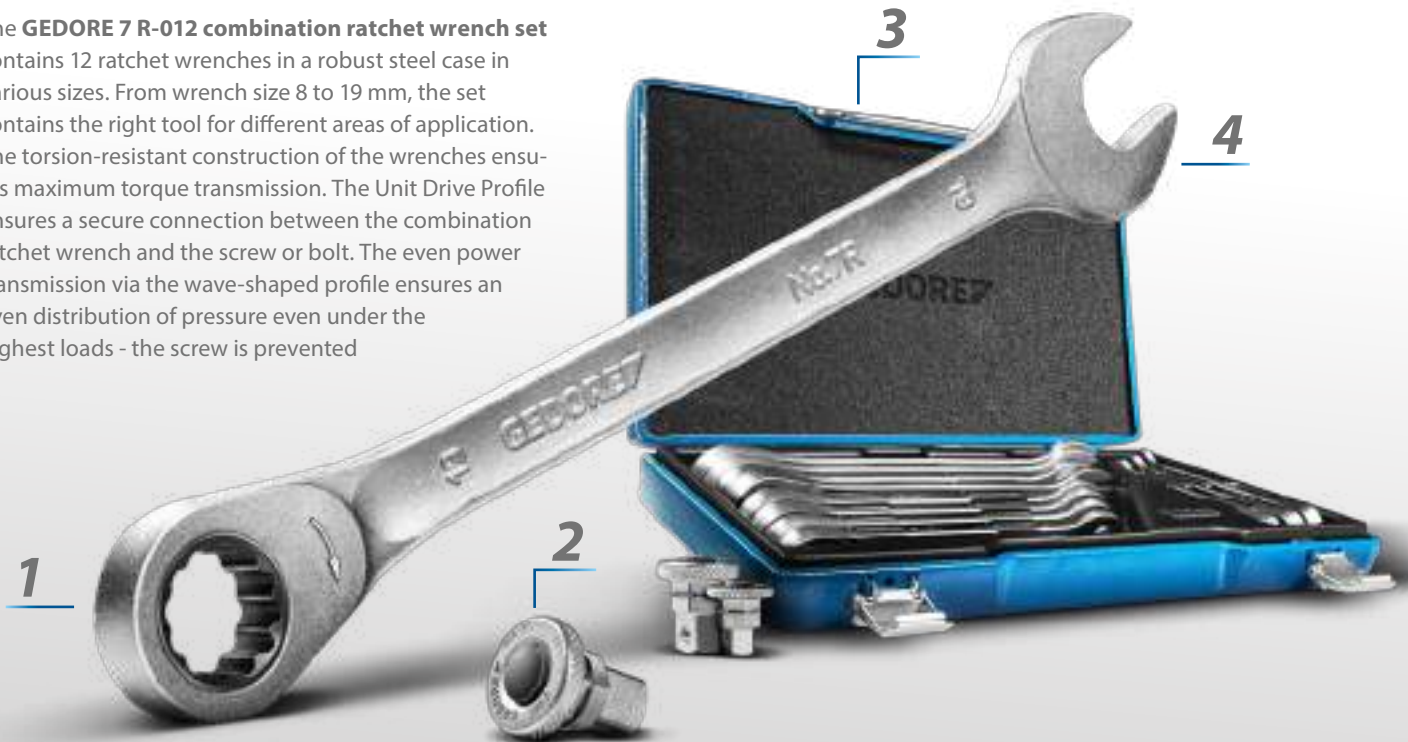

Set of open-end spanners with ring ratchet 7 R-012

1

UNIT DRIVE PROFILE (UD)

- Even power transmission thanks to the wave profile - this protects the screw from damage and ensures a secure hold even under the highest loads

2

RATCHET FUNCTION

- In conjunction with an adapter, the wrench quickly becomes a ratchet that can also be used in tight spaces thanks to its low overall height

3

COMPACT METAL CASE

- Safely sorted and stowed in the blue box with plastic insert

4

OPEN-END WRENCH AND RING RATCHET IN ONE TOOL

- On one end precise mouth: ground to the exact nominal size for optimal contact surfaces. On the other end is a ratchet wrench with the proven mechanism of the U-20 ratchet for ratcheting loosening or quick tightening



„With the combination ratchet wrench set 7 R-012, you always have the most common sizes of the practical GEDORE classic at hand.“

7 R-012
COMBINATI-
ON RATCHET
SPANNER
SET
12 pieces

€194,¹²
+ VAT



- › Practical combination of open-end wrenches with ring ratchet with the same width across flats
- › For ratchet loosening and fast tightening of bolts and nuts
- › High torque transmission enables efficient, ratcheting work
- › Wrench box made of sheet metal with plastic insert

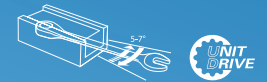

Code	No.	Contents	Length mm	Pieces	Weight kg
2297442	7 R-012	7 R 8 9 10 11 12 13 14 15 16 17 18 19	320	12	2.84

7 RA
ADAPTOR FOR
7 R/7 UR

€9,⁰⁷
+ VAT

from



- › The adaptor transforms the ring ratchet spanner into a ratchet
- › With push-button release, wear-resistant and manganese phosphated
- › Fast-turning ring for swift release or tightening
- › Secure adaptor fit in the ring ratchet thanks to circlip

Code	No.	Width Across Flat of Drive	Drive connector square female	Drive connector square female mm	Height mm	Weight kg	excl. VAT
2320495	7 RA-6,3	10	1/4"	6,3	18	0.011	9,07
2320487	7 RA-10	13	3/8"	10,0	24	0.03	9,99
2320479	7 RA-12,5	19	1/2"	12,5	32	0.07	10,83

7 RA 183
RATCHET
SPANNER SET
with plier, 10 pieces

€157,⁹⁸
+ VAT



- › Practical set for through bolts. For countering and counter-holding with the same width across flats
- › Ring ratchet wrench set with low body height and small swingback angle of 5 - 7
- › Flat pliers wrench with SW 0 - 42 or 1.5/8" including jaws for surface-friendly gripping included in the set
- › With adapter (1/4", 1/2") for the use of sockets on the ring ratchet wrench
- › Optimal extension to the socket set 19 DMU-20 (3014347)
- › Housed in plastic box with Checktool insert



Code	No.	Contents	Width mm	Height mm	Depth mm	Pieces	Weight kg
3416356	7 RA 183	7 R Open-end spanner with ring ratchet 8 10 13 17 19 mm 7 RA-12,5 Adapter 1/2" 19 mm, 7 RA-6,3 Adapter 1/4" 10 mm 183 7 TC Pliers spanner incl. jaws, WK 19DM/IN19 L Box empty EI-7 RA 183 Foam insert empty	360	70	190	10	1.7

1 B-0112

COMBINATION SPANNER SET

metric, 12 pieces



- > With UD profile for easy power transmission, from SW 1.3/8"
- 12-edge ring
- > Ring cranked and angled 10°
- > For actuating recessed or deep-set nuts or screws

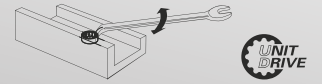

Code	No.	Contents
6012840	1B-0112	6 7 8 9 10 11 12 13 14 15 17 19 mm

Pieces	Weight kg
12	0.925

7-0112

COMBINATION SPANNER SET

metric, 12 pieces



- > Practical composition
- > With same size each end
- > Ring angled 15°, with UD profile - for gentle force transmission
- > Jaw position 15°, precisely ground to exact nominal dimension for optimum contact surfaces



Code	No.	Contents
6091530	7-0112	6 7 8 9 10 11 12 13 14 15 17 19 mm

Pieces	Weight kg
12	0.686

7-012

COMBINATION SPANNER SET

metric, 12 pieces



- > Practical composition
- > With same size each end
- > Ring angled 15°, with UD profile - for gentle force transmission
- > Jaw position 15°, precisely ground to exact nominal dimension for optimum contact surfaces

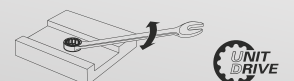

Code	No.	Contents
6093150	7-012	10 11 12 13 14 17 19 22 24 27 30 32 mm

Pieces	Weight kg
12	2.7

ROBUST AND DURABLE

7 XL-080 COMBINATION SPANNER SET

extra long, 8 pieces

€81,²⁵
+ VAT



- › Same size each end
- › Extra long shaft for deep range of use and more torque
- › Slim jaw and jaw walls make this spanner lighter overall
- › Ring angled 15°, with UD profile - for gentle force transmission
- › Jaw position 15°, precisely ground to exact nominal dimension for optimum contact surfaces

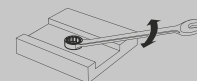

Code	No.	Contents
6104880	7 XL-080	8 9 10 11 13 14 17 19 mm

Pieces	Weight kg
8	0.962

4-120 DOUBLE ENDED RING SPANNER SET

12 pieces

€133,⁶¹
+ VAT



- › Practical composition
- › With different wrench sizes
- › Flat pattern
- › Thin walled rings



Code	No.	Contents
6062190	4-120	6x7 8x9 10x11 12x13 14x15 16x17 18x19 20x22 21x23 24x27 25x28 30x32 mm

Pieces	Weight kg
12	2

BIT SET 1/4" WITH RATCHET IN A CLEARLY ARRANGED MINI BOX

A 38 part bit set in a practical Mini L-Boxx. From bits and inserts to extensions, ratchets and multi-handles; the set offers a solution for all conceivable 1/4" applications in . And although there is so much in it, everything has room in a practical Mini L-Boxx.

The 38-piece 1/4" bit set FLEX 1102-038 from GEDORE is perfect for universal use, e.g. for servicing and maintaining windows. The standard bits and inserts included in the set cover the majority of applications. With the included 1/4" reversible ratchet and the multi-handle, you are prepared for changing applications, including different heights. The different lengths of the adapters also help to adapt to changing applications, they can also be used with a cordless screwdriver, for example. The set is rounded off by a practical Mini L-Boxx, which allows an immediate view of the contents through the transparent lid.



Bit Set 1/4" FLEX 38 pieces 1102-038

1

LOTS OF ACCESSORIES

- Adapters with different lengths enable optimal adjustment to the screw depth

2

PRACTICAL MINI L-BOXX

- The transparent lid enables a direct view of the contents of the box and prevents tiresome searching

3

FLEXIBLE USAGE

- Whether delicate screwing with the multi-handle or applying higher forces with the reversible ratchet, both are possible with this set

4

MOST COMMON BITS AND INSERTS

- Covering a wide range of applications and therefore universally usable



BIT SET WITH FLEXIBILITY AND QUALITY

„These bits have been in use in our workshop for years and are still alive, which is something you really can't say about 08 15 tools. I have now bought the item for my private workshop because I am convinced of it.“



NEW

1102-038
BIT-SET 1/4" FLEX
 38 pieces



- > 38-piece bit set with selected adapters and inserts
- > 1/4" reversible ratchet bit and multi-handle screwdriver for optimal work
- > 5 adapters give max flexibility when working
- > With 1/4" socket wrench inserts, 12-point UD profile (SW6,7,8,10,11,12,13)
- > With 1/4" bit sockets (IN,TX,PH,PZ)
- > 3 long offset screwdrivers (SW4,5,6) for the most common applications
- > In Mini L-boxx with Checktool insert for overview and quick access

€108,40
+ VAT

Code	No.	Contents	Width mm	Height mm	Depth mm	Pieces	Weight kg
3437450	1102-038	Bit ratchet 1/4" hexagon socket Multi-grip 1/4" hex socket Bit holder 1/4" with quick release system, 60 mm Bit holder 1/4" with magnetic holder, 60 mm Bit holder 1/4" with magnetic holder, 130 mm Insert holder 1/4" square, 130 mm Insert holder 1/4" square, 17 mm Socket 1/4", double hexagon SW 6 7 8 10 11 12 13 1/4" Phillips PH 2 3, 50 mm 1/4" Phillips PH 1 2 3, 25 mm 1/4" Phillips PZD 2 3, 50 mm 1/4" Phillips PZD 1 2, 25 mm 1/4" bits, hexagon socket SW 2 3 4 5 6, 25 mm 1/4" Bits, TX T10 T15 T20 T25 T27 T30 T40, 25mm Allen key, long, hexagon socket SW 4 5 6	260	65	155	38	0.918

666-006 BIT BOX SOCKET MACHINE MOUNT

6 pieces

€29,⁸²
+ VAT



- › Socket wrench inserts with magnet for damage-free insertion and removal of hexagon head screws
- › Especially suitable for self-drilling screws
- › Box made of plastic with a transparent lid for quick checking of tools

6 mm 1/4" AF 1/4" 6.3

Code	No.	Contents	Width mm	Height mm	Depth mm	Pieces	Weight kg
2993244	666-006	Socket wrench machine mount 1/4" 7 8 10 12 13 mm and 3/8"	143	42	107	6	0.24

666-032-A BIT-BOX ALLROUND

32 pieces

€18,⁰⁶
+ VAT



- › For industry, the tradesmen and DIY
- › 1/4" bit holder with quick-grip system
- › Made in Germany

6.3 1/4"

Code	No.	Contents	Pieces	Weight kg
2993236	666-032-A	Screwdriver bit 1/4" for slotted screws No. 680 4.5 (1x) 5.5 (2x) 6.5 (1x) Screwdriver bit 1/4" for cross-head screws PH No. 690 1 (2x) 2 (3x) 3 (1x) Screwdriver bit 1/4" for cross-head screws PZ No. 690 PDZ 1 (2x) 2 (4x) 3 (1x) Screwdriver bit 1/4" for inside TX screws No. 687 TX T10 (1x) T15 (1x) T20 (2x) T25 (3x) T30 (2x) T40 (1x) Screwdriver bit 1/4" for multi-tooth socket screws XZN No. 685 X 3 (1x) 4 (1x) 5 (1x) 6 (1x) Bit holder 1/4", magnetic No. 700	32	0.246

666-042 TORSIONS BIT SET

42 pieces

€36,¹³
+ VAT



- › Torsion zone to protect bits under load. Peak torques are gently cushioned, which increases the lifetime
- › Includes an extremely slender self-securing magnetic bit holder with quick-release function
- › For soft and hard bolting tasks
- › Suitable for use in Impact sockets

1/4" 6.3 1/4" 6.3

Code	No.	Contents	Width mm	Height mm	Depth mm	Pieces	Weight kg
3100316	666-042	1/4" bits, 25mm: 1/4" slotted 5.5, 6.5, 1/4" Phillips PH 1 2 2 3 1/4" Phillips PZ 1 2 2 3 1/4" TX T10 T15 T20 T25 T30 T40, 1/4" bits, 50mm 1/4": hexagon 3 4 5 mm 1/4" Phillips PH 1 2 2 3, 1/4" Phillips PZ 1 2 2 3, 1/4" TX T10 T15 T20 T25 T30 1/4" bits, 88.9mm: 1/4" slot 5.5mm, 1/4" Phillips PH 2 1/4" Phillips PZ 2, 1/4" TX T25 Drive adapter 1/4" 6kt x 1/4" 4kt, L. 50mm Drive adapter 1/4" 6kt x 3/8" 4kt, L. 50mm Socket, magnetic, with 1/4" hex drive SW 8mm, L.67mm Socket, magnetic, with 1/4" hex drive SW 10mm, L.67mm Socket, magnetic, with 1/4" hex drive SW 13mm, L.67mm Bit holder 1/4" One-touch Slim Lock, L.66.5mm	190	45	120	42	0.67

670
BIT SCREWDRIVER 1/4"

- > With hexagon drive as per DIN ISO 1173 for Bits
- > With strong magnetic holder



€15,37
+ VAT



Code	No.	Drive connector hexagon female	Drive connector hexagon female mm	Blade length	Total length mm	Weight kg
6536590	670	1/4"	6.3	100	210	0.14

2169-012
MAGAZINE HANDLE SCREWDRIVER
WITH RATCHET FUNCTION
SILENTGEAR 1/4"

- > Loaded magazine screwdriver with ratchet function
- > For precision working in confined spaces
- > Very small return angle, practically 0° (not measurable with mechanical measuring equipment)
- > Rotating ring for clockwise/anticlockwise rotation adjustment, screw tightening also without ratchet function due to neutral central position with ratchet lock



€31,67
+ VAT



Code	No.	Content	Drive connector hexagon female inch	Drive connector hexagon female metric	Length mm	Handle width mm	Weight kg
3031691	2169-012	SL 0,8x4,5 1,0x5,5 1,2x6,5 PH 1 2 3 PZ 1 2 TXT10 T15 T20 T25	1/4"	6.3	250	38,6	0.235

2675
RATCHET SCREWDRIVER
SILENTGEAR 1/4" BIT HOLDER

- > Highly compact ratchet screwdriver
- > For precision working in confined spaces
- > Very small return angle, practically 0° (not measurable with mechanical measuring equipment)
- > Rotating ring for clockwise/anticlockwise rotation adjustment, screw tightening also without ratchet function due to neutral central position with ratchet lock



€13,61
+ VAT



Code	No.	Drive connector hexagon female inch	Drive connector hexagon female metric	Length mm	Weight kg
3031918	2675	1/4"	6,3	225	0.14

2 IN 1 SOCKET WRENCH IN RANK AND FILE

Socket strip with inserts - a lot of tools in a small space.

The **socket strip with 1/2" sockets with C-profile SB C19 SL-010** from **GEDORE** is ideal for flexible attachment at the workplace and guarantees quick access to the tool. If required, there are additional slots for inserts. The 16-way header is preloaded with 10 inserts. The inserts are not only suitable for metric sizes, thanks to the C-profile they can also be used on inch screw connections without any problems.

Thanks to the high power transmission of the C-profile, the screw heads are protected, and damaged screw connections can also be easily loosened. The plug-in strip is not only perfect for storing inserts, there is also space for e.g. ratchets and sliding handles with a 1/2" square drive.

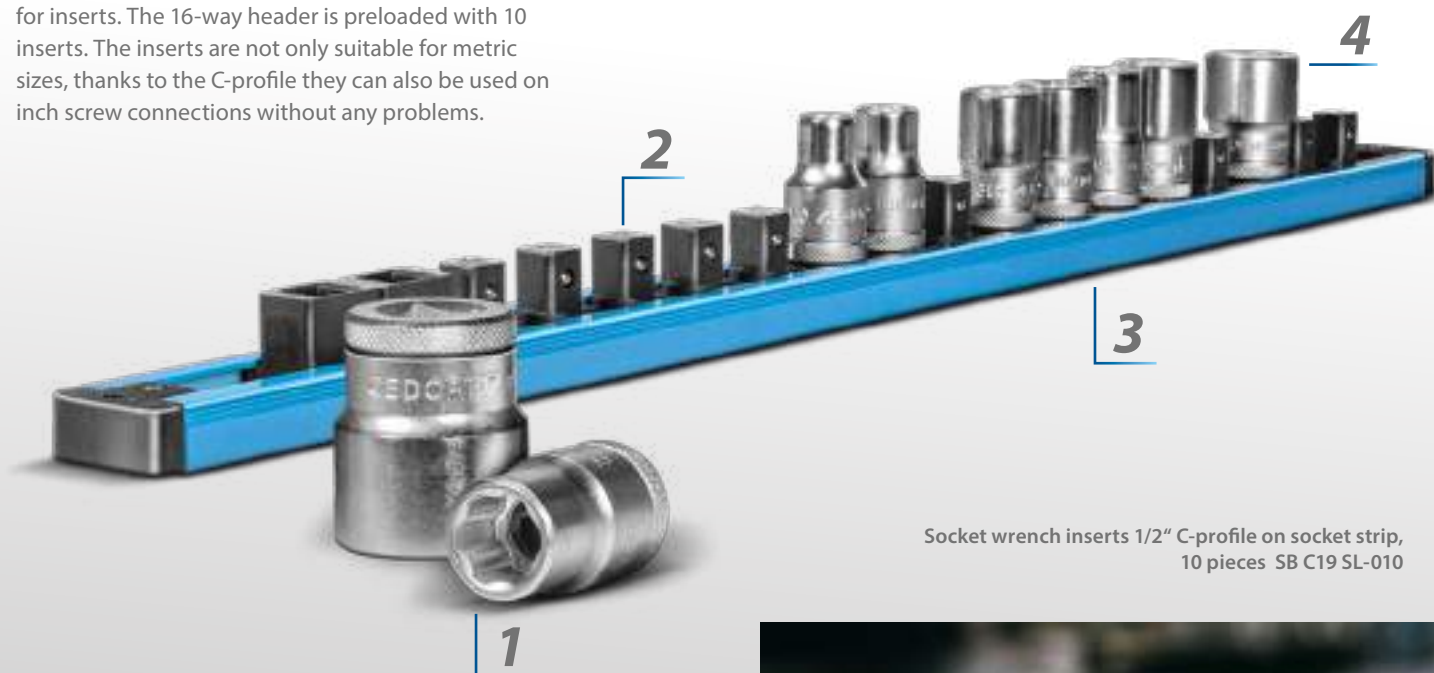

Socket wrench inserts 1/2" C-profile on socket strip, 10 pieces SB C19 SL-010

1

GENTLE ON THE SCREW HEAD

- High power transmission of the C-profile protects the screw heads

2

FLEXIBLY EXPANDABLE

- Can be expanded to include additional inserts as required

3

EVERYTHING AT HAND

- Fastening socket wrench inserts and e.g. ratchets

4

2 IN 1

- C-profile inserts designed for metric and imperial screw connections



ALWAYS
AT HAND

"Super easy for on the go work or as an addition to the tool wall. You have everything to hand."



NEW

SB C19 SL-010
SOCKET WRENCH INSERTS 1/2"
C-PROFILE ON HEADER

10 pieces

- > Suitable for metric and imperial screws
- > Magnetic connector strip with mounting holes for flexible or fixed mounting
- > 4 free slots for additional inserts with 1/2" mount
- > Fixed locking of the inserts by 90° rotation (ball lock)
- > 10 sockets 1/2" with C-profile (Contact Drive)
- > 16 slots (14 x 1/2" square drive, 2 x 1/2" square drive)
- > C-profile enables protection of the screw head



€63,¹⁸
+ VAT

Code	No.	Contents	Length mm	Pieces	Weight kg
3437442	SB C19 SL-010	Socket strip 1/2", SL 1916 C profile 1/2" SW 10 12 13 15 16 17 18 19 22 24	580	10	1.28

SOCKET WRENCH SET FOR IMPACT WRENCH SW 10 - 24

Nuts for all compressed air and electric screwdrivers with ball lock.

The 7-piece 1/2" **power screwdriver set K 19-007** from **GEDORE** is ideal in combination with hand tools or screws for all repair and assembly work. The set consists of the most common sizes of SW 10-24 and leaves nothing to be desired for various applications. Thanks to the included 1/2" power wrench extension, even low-lying screw connections can be loosened easily. With the ball lock, the nuts are securely connected to the output and the change is still easy and uncomplicated. The set is stowed in a compact plastic case - perfect for storage or on the go.



Impact wrench set 1/2" 7 pieces K 19-007

1

COMPACTLY STOWED AWAY

- Everything is stored in a compact plastic case, ready to use

2

MOST POPULAR SIZES

- Set consisting of the most common sizes from SW 10-24

3

SECURE CONNECTION

- The ball lock connects the nuts firmly to the machine, but the change is easy and uncomplicated

4

SCREWS WITH DEPTH

- Extension for low-lying screw connections included in the set

SCREWS WITH
POWER

„The nuts are very comfortable to hold, it's fun to work with, and the quality is very good. I do a lot of work on my car and can only recommend the set.“



NEW

K 19-007
SCREWDRIVER SET 1/2"
 7 pieces

- > 6 power screwdriver sockets suitable for all common compressed air and electric screwdrivers
- > With square drive according to DIN 3121 - G12.5, ISO 1174
- > 1 power screwdriver extension 75 mm with ball lock on the square
- > Surface phosphated
- > In a plastic box



€45,¹²
 + VAT

Code	No.	Contents	Width mm	Height mm	Depth mm	Pieces	Weight kg
3437426	K 19-007	1/2" impact sockets hexagon, SW 10 13 17 19 21 24 1/2" impact socket extension KS, 75 mm	215	50	120	7	1.1

D 20 KMU-20
**SOCKET
 SET 1/4"**
 37 pieces

€116,⁸¹
 + VAT



- > Forged, tempered hexagon (No. 32) UD profile sockets, hand-operated
- > With actuation tools
- > With robust lever-change reversible ratchet, with push-button release
- > In plastic case

6,3 1/4" 6,3 1/4" mm

Code	No.	Contents	Width mm	Height mm	Depth mm	Pieces	Weight kg
1822373	D 20 KMU-20	Ratchet 2093 U-20 Inserts D 20 4 5 6 7 8 9 10 11 12 13, 680 4 5 5 6 5, 685 3 4 5 6 685 X 5 6 8, 687TX T10 T15 T20 T25 T27 T30 T40, 690 1 2, 690 PZD 1 2 3 Accessories 1/4" extension 2090-4, 620, 1/4" Multi-Grip 676, 699	202	38	119	37	0.712

D 20 MOT
**BASIC TOOL
 SET 1/4" FOR
 MOTORBIKES**
 30 pieces

€116,⁸¹
 + VAT



- > Selected tools with metric dimensions for „first aid“ on the motorcycle
- > In plastic case

6,3 1/4" 6,3 1/4" mm

Code	No.	Contents	Width mm	Height mm	Depth mm	Pieces	Weight kg
2190281	D 20 MOT	T-handle ratchet 1/4" No. 2093 U-3 T, Socket 1/4" 12-point UD profile No. D 20 8 9 10 11 12 13 14 Screwdriver bit 1/4" for Allen screws No. 685 3 4 5 6 8 10 Screwdriver bit 1/4" for internal serration screws XZN No. 687 TX T10 T15 T20 T25 T27 T30 T40 Screwdriver bit 1/4" for Phillips screws PH No. 690 1 2 3 Screwdriver bit 1/4" for slotted screws No. 680 4 6 5 Cardan extension 1/4" No. 2090 KR-4, Extension 1/4" No. 2090-6 Cardan joint 1/4" No. 2095, Bit adapter 1/4" No. 620	203	38	123	30	0.572

D 20 DMU-3
SOCKET SET 1/4"
 14 pieces

€90,⁶⁷
 + VAT



- > Hand-operated 12-point UD profile sockets and operating tools
- > With fine toothed, dial change ratchet
- > In plastic case

6,3 1/4" mm

Code	No.	Contents	Width mm	Height mm	Depth mm	Pieces	Weight kg
1815598	D 20 DMU-3	Reversible ratchet 1/4" No. 2093 U-3 Socket 1/4" 12-point UD profile No. D 20 4 4 5 5 5 5 6 7 8 9 10 11 12 13 Extension 1/4" No. 2090-4	140	47	95	14	0.429

30 IMU-10 SOCKET SET 3/8"

26 pieces

€189,⁹²
+ VAT



- > Hand-operated hexagonal UD profile sockets
- > With actuation tools
- > Set U-10 with reversible lever change ratchet
- > In GEDORE blue sheet steel case

10 3/8" mm

Code	No.	Contents	Width mm	Height mm	Depth mm	Pieces	Weight kg
6229740	30 IMU-10	reversible ratchet 3/8" No. 3093 U-10 200 mm Cross handle 3/8" No. 3087 Extension 3/8" No. 3090-5 125 mm Extension 3/8" No. 3090-10 250 mm Cardan joint 3/8" No. 3095 51 mm Socket wrench insert 3/8" No. 30 hexagon 6 7 8 9 10 11 12 13 14 15 16 17 19 mm Screwdriver bit socket 3/8" No. IS 30 slot 5.5x1 8x1.2 mm Screwdriver bit socket 3/8" No. IN 30 hexagon socket 4 5 6 mm Screwdriver bit socket 3/8" No. IKS 30 Phillips PH 2 3	320	55	210	26	3.1

D 30 KMU-20 SOCKET SET 3/8"

40 pieces

€226,⁰⁵
+ VAT



- > Hand-operated 12-corner UD-profile sockets
- > With actuation tools
- > With robust lever-operated reversible ratchet and cross-handle ratchet
- > In GEDORE blue sheet steel case

10 3/8" mm
6,3 1/4"

Code	No.	Contents	Width mm	Height mm	Depth mm	Pieces	Weight kg
1973347	D 30 KMU-20	Reversible ratchet 3/8" No. 3093 U-20 Reversible ratchet 3/8" No. 3093 U-3 T Socket 3/8" 12-point UD profile No. D 30 8 9 10 11 12 13 14 15 16 17 18 19 Screwdriver bit 1/4" for slotted screws No. 680 4 5 5 6 5 Screwdriver bit 1/4" for Allen screws No. 685 3 4 5 6 Screwdriver bit 1/4" for internal serration screws XZN No. 685 X 5 6 8 Screwdriver bit 1/4" for internal TX screws No. 687 TX T10 T15 T20 T25 T27 T30 Screwdriver bit 1/4" for Phillips screws PH No. 690 1 2 Screwdriver bit 1/4" for Phillips screws PZ No. 690 PZD 1 2 Cardan extension 3/8" No. 3090 KR-3, Extension 3/8" No. 3090-5 Bit adapter no. 630, Insert holder no. 673 10 Multi grip no. 676 Bit holder for machine screwdriver no. 699	320	55	210	40	2.6

19 V20U-10

SOCKET SET 1/4"+1/2"

50 pieces

- > With forged, tempered, manually operated double hex sockets
- > With accessories made from vanadium steel 31CrV3
- > Nominal size 6.3 (1/4") with extra fine-toothed reversible ratchet U-3
- > Nominal size 12.5 (1/2") with robust lever-operated reversible ratchet, with push-button release U-10 T
- > In GEDORE blue sheet steel case

€368,⁹¹
+ VAT



Code	No.	Contents	Width mm	Height mm	Pieces	Weight kg
6157490	19 V20 U-10	Ratchet 1/2" 1993 U-10 T, 1/4" 2093 U-3 Inserts 1/2", 19 10 11 12 13 14 15 17 19 22 24 27 30 IN 19 7 8 10 12 14, IS 19 8 10, ICS 19 3 1/4", 20 4 4, 5 5, 5, 6 7 8 9 10 11 13, IN 20 3 4 5 6, IS 20 4 5, 6, 5, ICS 20 1 2 Accessories 1/2" extension 1990-5-10 1/2" universal joint 1995 1/4" square plug-in handle 2098 1/4" extension 2090-2-4 1/4" cross handle with sliding piece 2087 1/4" universal joint 2095	280	57	50	6.2

19 DMU 183

SOCKET SET

with pliers spanner,
18 pieces

€239,⁵⁰
+ VAT



- > 1/2" ratchet set with gimbal extension and pliers wrench size 7 (0-42mm / 0-1.5/8")
- > Proven 1993 U-20 ratchet and inserts with hexagonal UD profile (10-32 mm)
- > Flexible use up to SW 42 mm with pliers wrench
- > Incl. protective jaws for pliers wrench for surface-friendly gripping
- > Checktool insert in compact plastic case with viewing window

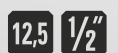

Code	No.	Contents	Width mm	Height mm	Depth mm	Pieces	Weight kg
3416321	19 DMU 183	1993 U-20 reversible ratchet 1/2" 19 Socket 10 12 13 15 16 17 18 19 22 24 27 30 32 1990 KR-5 Gimbal Extension 1/2" 183 7 TC pliers wrench including protective jaws WK 19DM/IN19 L box empty EI-19 DMU 183 foam insert empty	360	70	190	18	3.1

VERSATILE USABLE

19 BMC 20 SOCKET SET 1/4"+1/2"

69 pieces



- › The GEDORE plastic ratchet box is suitable for industry, automotive as well as DIY & hobbyists
- › It is equipped with a black/blue foam check tool insert that makes missing tools easily visible
- › The droplet-like head of the reversible ratchets make this set ideal for the tightest of bolting positions
- › The reversible ratchets features a dual material handle, lever change and press-button release for easy, rapid and safe working
- › Depending on the wrench size, the sockets can be extended up to 375 mm in the drive depth



Code	No.	Contents	Length mm	Width mm	Height mm	Pieces	Weight kg
3108902	19 BMC 20	Ratchets 1/4" + 1/2, Reversible ratchets 1/4" 2093 U-20 reversible ratchets 1/2" 1993 U-20, Socket wrench inserts 1/4" + 1/2 Hexagonal inserts 1/4" 4 4,5 5,5 6 7 8 9 10 11 12 13 14 mm Hexagonal inserts 1/2" 15 16 17 18 19 21 22 24 27 30 32 mm Hexagonal inserts long 1/2" 10 13 17 19 mm, Bits 1/4 Hexagon socket 2 3 4 5 6 8 mm, TX;with bore T10 T15 T20 T25 T27 T30 T40 Slot 4 5 5.5 6 8 mm, Cross recess PH 1 2 3 Cross recess PZ 1 2 3, Multi-tooth XZN M4 M5 M6 M8 Accessories 1/4" + 1/2, Extension 1/4" 50 100 mm Adaptor 1/4" x 1/4", Bit-Holder 1/4", T-handle 1/4", Cardan joint 1/4 Extension 1/2" 125 250 mm, Cardan joint 1/2, T-Handle 1/2"	460	355	86	69	5.7

19 EMU-20
SOCKET
SET 1/2"
23 pieces

€234,⁴⁵
+ VAT



- > Hand-operated hexagonal UD profile sockets
- > With actuation tools
- > Set U-20 with robust lever-change reversible ratchet, with easy push-button release
- > In GEDORE blue sheet steel case

12,5 1/2" mm

Code	No.	Contents	Width mm	Height mm	Depth mm	Pieces	Weight kg
2545837	19 EMU-20	Reversible ratchet 1/2" No. 1993 U-20 Socket 1/2" hexagon UD profile No. 19 8 9 10 11 12 13 14 15 16 17 18 19 21 22 24 27 30 32 T-handle 1/2" No. 1987, Extension 1/2" No. 1990-5 -10, Cardan joint 1/2" No. 1995	425	57	280	23	5.7

19 SKU-20
SOCKET
SET 1/2"
14 pieces

€225,²¹
+ VAT



- > Hand-operated socket wrench inserts no. 19 SK for threaded and bolt fittings
- > With robust lever-change reversible ratchet with in-hex drive
- > Fine toothed, return angle 6°, low overall height
- > In GEDORE blue sheet steel case

UNIT RIVE mm

Code	No.	Contents	Width mm	Height mm	Depth mm	Pieces	Weight kg
2521563	19 SKU-20	Ratchet 1993 U-20 SK Inserts 19 SK 10 11 12 13 14 15 16 17 18 19 21 22 24	320	55	132	14	1.7

19 DMU-20
SOCKET
SET 1/2"
15 pieces

€171,⁴³
+ VAT



- > With hand-operated hexagonal UD profile sockets
- > With actuation tools
- > With robust lever-change reversible ratchet, with push-button release
- > With universal extension, is able to pivot up to 15°

12,5 1/2" mm

Code	No.	Contents	Width mm	Height mm	Depth mm	Pieces	Weight kg
3014347	19 DMU-20	Reversible ratchet 1/2" No. 1993 U-20 Socket 1/2" hexagon UD profile No. 19 10 12 13 15 16 17 18 19 22 24 27 30 32 Cardan extension 1/2" No. 1990 KR-10	380	70	190	15	2.9

19 KMU / D 19 KMU SOCKET SET 1/2"

13 pieces

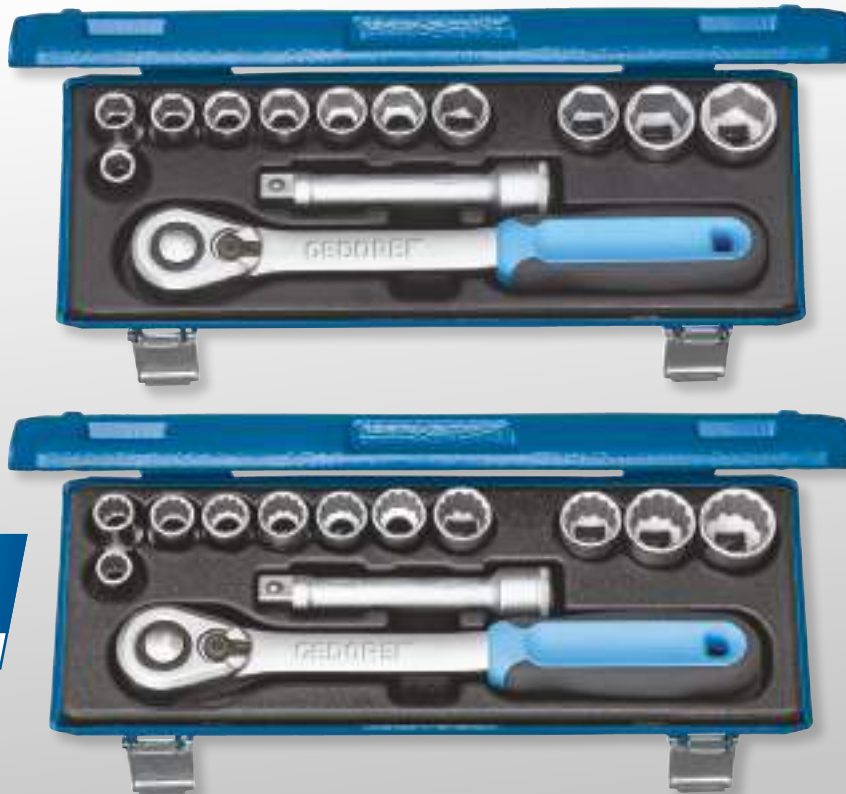

- > Hand-operated 6-sided UD profile (No. 19) or 12-sided UD profile (No. D 19) sockets
- > With actuation tools
- > With robust lever-change reversible ratchet, with push-button release
- > In GEDORE blue sheet steel case

€152,⁹⁴
+ VAT

12,5 1/2" mm

Code	No.	Contents	Width mm	Height mm	Depth mm	Pieces	Weight kg	excl. VAT
2545810	19 KMU-20	Reversible ratchet 1/2" No. 1993 U-20 Socket 1/2" hexagon UD profile No. 19 10 12 13 14 15 16 17 18 19 22 24 Extension 1/2" No. 1990-5	320	55	210	13	2.6	152,94
2545829	D 19 KMU-20	Reversible ratchet 1/2" No. 1993 U-20 Socket wrench insert 1/2" 12-point UD profile No. D 19 10 12 13 14 15 16 17 18 19 22 24 Extension 1/2" No. 1990-5	320	55	210	13	2.6	152,94

19 JMU-3 SOCKET SET 1/2"

19 pieces



- > Hand-operated hexagonal UD profile sockets
- > With actuation tools
- > With fine toothed, dial change ratchet
- > In GEDORE blue sheet steel case

€206,⁷²
+ VAT

12,5 1/2" mm

Code	No.	Contents	Width mm	Height mm	Depth mm	Pieces	Weight kg
2682842	19 JMU-3	Reversible ratchet 1/2" No. 1993 U-3 Socket 1/2" hexagon UD profile No. 19 8 9 10 11 12 13 14 15 16 17 18 19 21 22 24 Extension 1/2" No. 1990-5 -10 Cardan joint 1/2" No. 1995	320	55	210	19	3.7

IN 19-009
**SCREWDRIVER
 BIT SOCKET SET**
 1/2"
 9 pieces

€90,67
 + VAT



- › Screwdriver set 1/2" for hexagon socket screws in sizes 4 - 14 mm
- › In a practical, robust plastic case
- › GEDORE Check-Tool-System: 2-colour foam insert to check that the set is complete

12,5 1/2"

Code	No.	Contents	Width mm	Height mm	Depth mm	Pieces	Weight kg
3014444	IN 19-009	Screwdriver bit socket 1/2" for hexagon socket screws No. IN 19 4 Screwdriver bit socket 1/2" for in-hex screws, long No. IN 19 L 5-90 6-90 7-140 8-140 9-140 10-140 12-140 14-140	360	70	190	9	1.9

D 32 EMU-2
SOCKET SET 3/4"
 14 pieces

€377,31
 + VAT



- › Hand-operated 12-point UD profile (No. D 32) sockets
- › With actuation tools
- › Set U-2 with fine toothed, dial change ratchet
- › In GEDORE blue sheet steel case

20 3/4" 6 mm  U-2

Code	No.	Contents	Width mm	Height mm	Depth mm	Pieces	Weight kg
6280420	D 32 EMU-2	Reversible ratchet 3/4" No. 3293 U-2 Socket wrench insert 3/4" 12-point UD profile No. D 32 22 24 27 30 32 36 38 41 46 50 Cross handle 3/4" No. 3287, Extension 3/4" No. 3290-8 -16	525	73	203	14	11.09

D 21 EMU-10
SOCKET SET 1"
 15 pieces

€881,51
 + VAT



- › Hand-operated 12-corner UD-profile sockets
- › With actuation tools
- › With robust lever-change reversible ratchet
- › In GEDORE blue sheet steel case

25 1" 6 mm

Code	No.	Contents	Width mm	Height mm	Depth mm	Pieces	Weight kg
6181600	D 21 EMU-10	Reversible ratchet head 1" No. 2193 U-10 K Socket 1" 12-point UD profile No. D 21 36 41 46 50 55 60 65 70 75 80 Extension 1" No. 2190-8 -16, T-handle 1" No. 2187 G 2187 K	765	105	289	15	32.8

S 2032-05
ADAPTOR SET
1/4" - 3/4"
 5 pieces



- › With reducers and enlargers from 1/4" to 3/4"
- › Reducers 1930, 3020
- › Enlarger pieces 2030, 3019, 1932
- › Please note the maximum load capacities of the outer square edge according to DIN 3123, ISO 3316

€45,²⁰_{+ VAT}

6,3 1/4" 10 3/8"
 12,5 1/2" 20 3/4"

Code	No.	Contents	Length mm	Width mm	Height mm	Pieces	Weight kg
1729071	S 2032-05	Enlargement piece 2030 1/4" - 3/8" (max. 62 Nm) Enlargement piece 3019 3/8" - 1/2" (max. 202 Nm) Enlargement piece 1932 1/2" - 3/4" (max. 512 Nm) Reducer 3020 3/8" - 1/4" (max. 62 Nm) Reducer 1930 1/2" - 3/8" (max. 202 Nm)	134	51	51	5	0.34

671
BIT RATCHET 1/4"

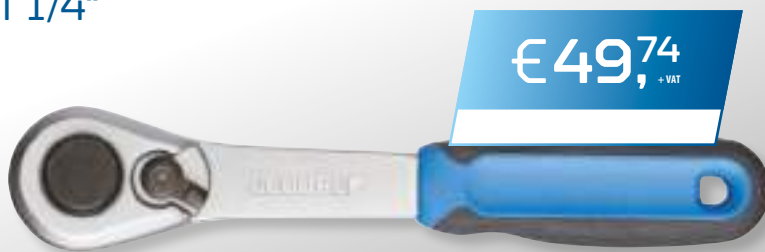

€49,⁷⁴_{+ VAT}

- › knurled head for quick starting or counter-holding of screws
- › Hexagon socket according to DIN ISO 1173
- › Slim line design for working in confined spaces

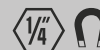

Code	No.	Drive connector hexagon female	Drive connector hexagon female mm	Return angle	Total length mm	Head height mm	Weight kg
6535350	671	1/4"	6,3	15°	127	18,3	0.108

2093 U-10
REVERSIBLE RATCHET 1/4"



€45,²⁰_{+ VAT}

- › Suitable for robust use in industry and commercial vehicles
- › Acc. to DIN 3122, ISO 3315
- › For hand-operated sockets and accessories with square drive as per DIN 3120 - C 6.3, ISO 1174, ball locking device

6,3 1/4"

Code	No.	Square drive inch	Square drive mm	Return angle	Length mm	Ratchet head height mm	Weight kg
6180470	2093 U-10	1/4"	6,3	15°	130	21,5	0.109

2093 U-3 T
RATCHET WITH T-HANDLE 1/4"



€27,¹³_{+ VAT}

- › Especially suitable for work in confined spaces
- › For hand-operated sockets and accessories with square drive as per DIN 3120 - C 6.3, ISO 1174, ball locking device

1/4"

Code	No.	Drive connector square	Drive connector square mm	Return angle	Total length mm	Weight kg
1791532	2093 U-3T	1/4"	6,3	5°	140	0.065

1993 U-10 L
REVERSIBLE RATCHET 1/2"
 Long pattern

€67,⁸¹
 + VAT

- › Acc. to DIN 3122, ISO 3315
- › With push-button release
- › For hand-operated sockets and accessories with square drive as per DIN 3120 - C 12.5, ISO 1174, ball locking device



Code	No.	Square drive inch	Square drive mm	Return angle	Length mm	Number of teeth	Weight kg
6154550	1993 U-10 L	1/2"	12,5	7,5°	350	48	0.62

1993 GU-10 XL
SWIVEL HEAD REVERSIBLE RATCHET 1/2"
 extra long

€107,⁵⁶
 + VAT

- › Extra long design
- › 180° pivotable
- › With push-button release
- › For hand-operated sockets and accessories with square drive as per DIN 3120 - C 12.5, ISO 1174, ball locking device



Code	No.	Square drive inch	Square drive mm	Return angle	Length mm	Weight kg
2018934	1993 GU-10 XL	1/2"	12,5	7,5°	615	1.16

1993 TU-10
TELESCOPIC REVERSIBLE RATCHET 1/2"

€107,⁵⁶
 + VAT

- › Long lever arm for high torques, max. torque 600 Nm
- › With push-button release
- › For hand-operated sockets and accessories with square drive as per DIN 3120 - C 12.5, ISO 1174, ball locking device



Code	No.	Square drive inch	Square drive mm	variable length	Return angle	Number of teeth	Weight kg
3041859	1993 TU-10	1/2"	12,5	400-600	7,5°	48	1.31

1993 U-20 G
REVERSIBLE RATCHET 1/2"
 with offset handle

€63,²⁷
 + VAT

- › Acc. to DIN 3122, ISO 3315
- › Fine-toothed (60 teeth), with lever change and push-button release
- › For hand-operated sockets and accessories with square drive as per DIN 3120 - C 12.5, ISO 1174, ball locking device



Code	No.	Drive connector square	Drive connector square mm	Return angle	Total length mm	Ratchet head height	Weight kg
2746786	1993 U-20 G	1/2"	12,5	6°	270	37,5	0.54

1993 GU-3

SWIVEL HEAD REVERSIBLE RATCHET 1/2"

- > 180° swivelling, with joint lock
- > With non-slip metal, fine-toothed (72 teeth) and robust
- > For hand-operated sockets and accessories with square drive as per DIN 3120 - C 12.5, ISO 1174, ball locking device



€58,73
+ VAT

1/2" 12,5

Code	No.	Drive connector square	Drive connector square mm	Return angle	Total length mm	Ratchet head height	Weight kg
6144320	1993 GU-3	1/2"	12,5	5°	282	40,5	0.535

3293 U-2

REVERSIBLE RATCHET 3/4"

- > Acc. to DIN 3122, ISO 3315
- > With disc change, fine-toothed and robust
- > For hand-operated sockets and accessories with square drive as per DIN 3120 - D 20, ISO 1174 with locking pin



€81,34
+ VAT

3/4" 20

Code	No.	Drive connector square	Drive connector square mm	Return angle	Total length mm	Ratchet head height	Weight kg
6278600	3293 U-2	3/4"	20	7,2°	510	60	1.435

3550-UK-LS4

TORQUE WRENCH TORCOFLEX UK SET 1/2"

40-200 Nm, 5 pieces

- > Tried-and-tested torque wrench in the 40-200 Nm range with test certificate
- > Controlled clockwise tightening; bi-directional reversible ratchet; 1/2" output drive
- > Classified as per DIN EN ISO 6789-2:2017; adjusted to a maximum permissible +/-3% deviation and thus with a greater precision than the standard-stipulated +/-4%
- > Highly suited for car tyre changing given its 1/2" extension and impact sockets with protective sleeve in the 17, 19 and 21 mm sizes



€152,94
+ VAT



Code	No.	Type	Square drive inch	Square drive metric mm	Contents	Nm	Height mm	Housing - square centre spacing mm	Length mm	Head width mm	Head height mm	Pieces	Weight kg
3107027	3550-UK-LS4	Reversible ratchet	1/2"	12,5	Torque wrench TORCOFLEX 40 -200 Nm No. 3550-20 UK extension no. 1990-5 Impact wrench set 1/2", 3 pieces	40-200	44	21,3	499	42,5	22	5	2.398

INDUSTRIAL GRADE PRECISION TORQUE WRENCH

The TORCOFIX is a torque wrench that allows the user easy adjustment and operation. With an adjusted accuracy of +/- 3% of the reading, the TORCOFIX resembles a Swiss watch.

The **TORCOFIX TF-K** from **GEDORE** offers the user significant advantages for optimal handling. The torque wrenches from 1-50 Nm are new, which extends the application range of the TORCOFIX TF-K from 1 - 850 Nm. The ergonomic handle ensures a centered hand position and thus good power transmission, the trigger signal can be clearly felt and heard. The torque is set intuitively using the twist grip, and locked securely using the end of the grip. The double scale with Nm and lbf-ft is located underneath a window with a magnifying glass effect for better readability. The triggering torque wrench with integrated ratchet and 1/4", 3/8", 1/2" and 3/4" drive can be easily switched

from left to right tightening. To do this, the mushroom head with ball lock is simply repositioned. Thanks to the robust, painted tubular steel construction, the TORCOFIX TF-K easily masters the high demands of industry and trade.

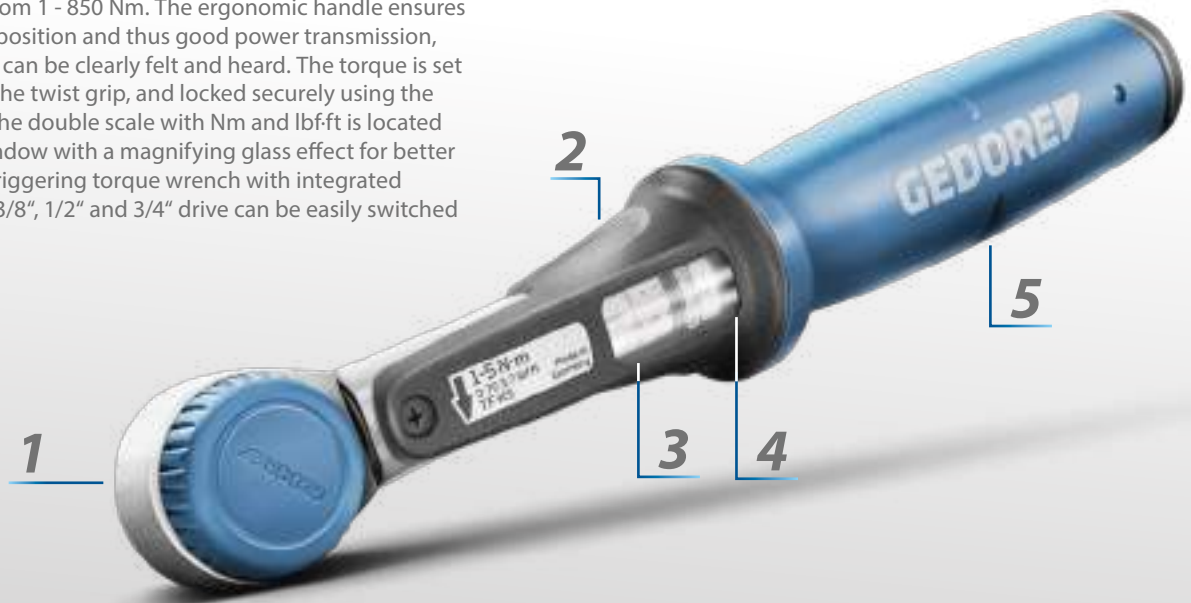

Torque wrench TORCOFIX TF-K 1/4"-3/4" 1-850 Nm TF-K

1

CONTROLLED TIGHTENING

- Controlled and precise screw tightening from 1 - 850 Nm
- Adjusted to a maximum deviation of +/- 3% and more precise than the +/- 4% required in the standard
- Including test certificate according to DIN EN ISO 6789-2:2017

2

SIMPLE AND EASY TORQUE ADJUSTMENT

- Thanks to the fixing depressions on the scale frame, there is optimal counter support when setting the torque

3

PERMANENTLY LEGIBLE

- Scaling and lettering protected under viewing window

4

IMPROVED READABILITY INCLUDING MAGNIFYING FUNCTION

- The optimized dual scale, the coloring and the central alignment of the main scale and the vernier ensure that the setting values are easier to read

5

INTUITIVE, ERGONOMIC APPLICATION

- The hand is centered in the middle of the handle thanks to the ergonomic shape of the handle.
- Clearly audible and tactile torque release



„The TORCOFIX offers the necessary precision for every screw and bolt connection that can or must be tightened with a torque wrench - that's quality Made in Germany.“

TF-K TORQUE WRENCH TORCOFIX TF-K

1-850 Nm / 0,75-630 lbf-ft

from

€143,70
+ VAT

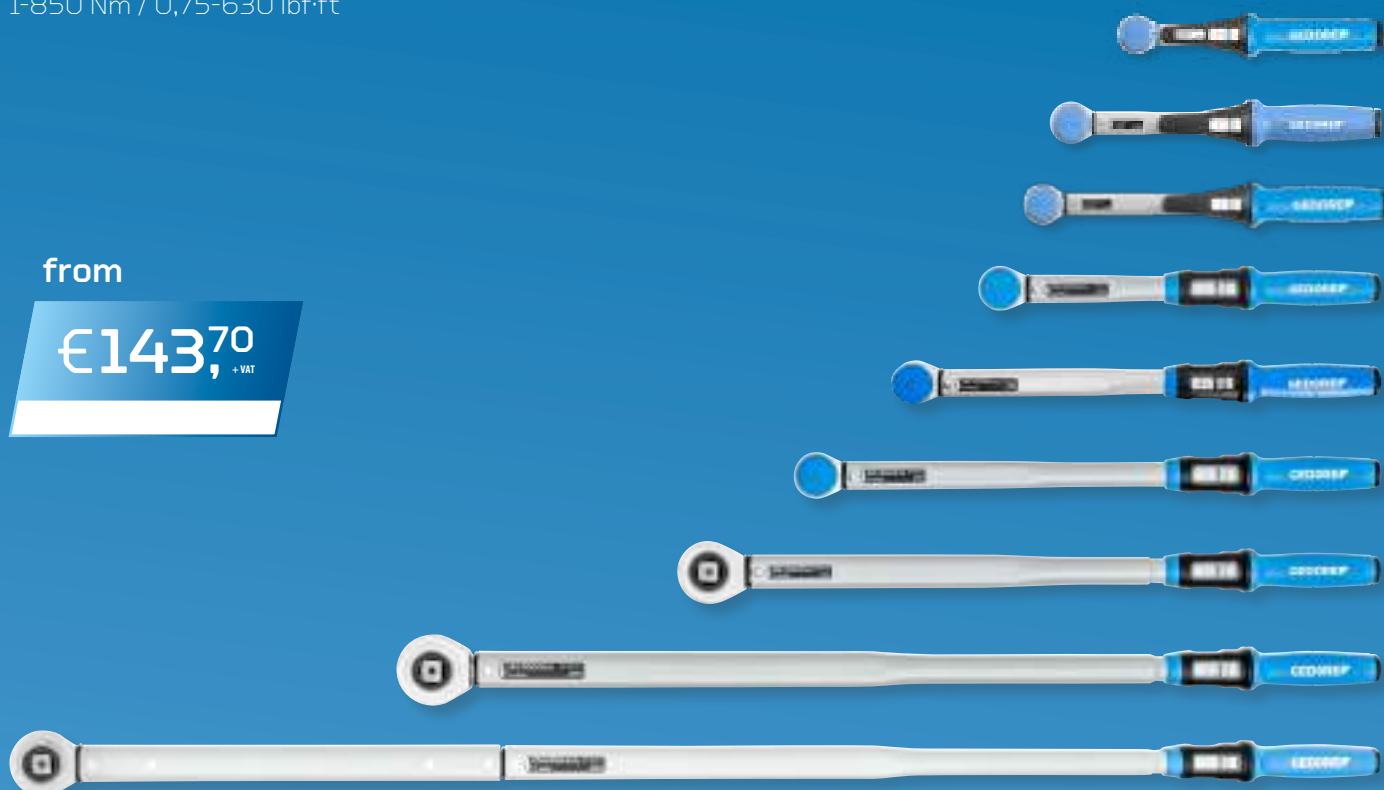

- > Controlled tightening in the most common range of 1 - 850 Nm / 0,75 - 630 lbf-ft
- > Adjustable, releasing and sturdy tubular torque wrench with integrated ratchet and with square drive for industry and the trades
- > Classified as per DIN EN ISO 6789-2:2017 Type II Class A; adjusted to a maximum permissible +/-3% deviation and thus with a greater precision than the standard-stipulated +/-4%
- > Incl. traceable test certificate (DIN EN ISO 6789-2:2017)
- > For controlled bi-directional tightening
- > 1/2" mushroom head square with ball lock. From 3/4" with square socket and pin retention
- > Robust, matt powder-coated tubular steel construction, with galvanized ratchet and high-quality plastic parts
- > New ergonomic handle, shaped according to the natural grip position of the hand
- > Clearly recognisable and tactile hand centring aid and calibration aid in the middle of the handle

- > With vernier scale for Nm main scale for setting intermediate scale values; lbf-ft setting only via main scale
- > Vertical alignment of the scale, torque adjustment therefore suitable for left and right handers
- > Scale line positioned directly above the scale prevents reading errors (parallax errors)
- > Unit inscription integrated in the scale frame and also protected against abrasion via viewing window,
- > Precise mechanism generates a clearly perceptible and audible trigger signal when the set torque value is reached
- > Incl. roll away protection, prevents rolling away when the tool is put down



Code	No.	Drive square inch	Drive square metric	Nm	lbf-ft	Scale division	vernier Nm	Length mm	Weight kg	excl. VAT
3288226	TF-K5	1/4"	6,3	1-5	0,75-3,7	0,25 Nm	0,025 Nm	150,5	0.33	143,70
3288234	TF-K25	1/4"	6,3	5-25	3,7-18	1 Nm	0,1 Nm	200,5	0.38	146,22
3288242	TF-K50	3/8"	10	10-50	7,5-37	2,5 Nm	0,25 Nm	230,5	0.42	150,42
3278379	TF-K100	1/2"	12,5	20-100	15-75	5 Nm	0,5 Nm	313,3	0.97	152,94
3278387	TF-K200	1/2"	12,5	40-200	30-150	10 Nm	1 Nm	404,3	1.18	161,34
3278395	TF-K300	1/2"	12,5	60-300	45-220	10 Nm	1 Nm	495,3	1.37	197,48
3278409	TF-K400	3/4"	20	80-400	60-300	10 Nm	1 Nm	593,3	1.93	333,61
3278492	TF-K550	3/4"	20	110-550	80-405	10 Nm	1 Nm	863,8	3.6	528,57
3278514	TF-K850	3/4"	20	250-850	185-630	10 Nm	1 Nm	1285,8	4.8	703,36

TORQUE WRENCH FOR INSERT TOOLS 9X12 MM / 14X18 MM

Adjustable, releasing and robust tubular torque wrench with square mount for industry and trade.

The **TORCOFIX SE** from **GEDORE** is a releasing torque wrench with a rectangular holder. Depending on the application, you can work from the front - for example with a socket wrench - or from the side - for example with a reversible ratchet and socket wrench insert. Ideal for assemblies in cramped and hard-to-reach places. The torque wrenches from 5-50 Nm are new, which extends the application range of the TORCOFIX TF-SE from 5 - 400 Nm. The variants are suitable for controlled right-hand and left-hand tightening. Using the torque wrench is easy and almost intuitive: The ergonomic handle promotes a centered hand position for good power transmission and at the same time transmits the trigger signal in a tactile manner. In addition, the torque is set using the rotary handle.

The set value is locked at the end of the handle. The double scale with Nm and lbf-ft is located underneath a window with a magnifying glass effect for better readability.



Torque wrench TORCOFIX SE 9x12 mm / 14x18 mm 5-400 Nm TF-SE

1

TOOL QUICK CHANGE SYSTEM

- Guaranteed flexible work - ideal for installations in tight and difficult-to-reach places with the 9x12 mm / 14x18 mm mount

2

EASIER TORQUE ADJUSTMENT

- Thanks to the fixing depressions on the scale frame, there is optimal counter support when setting the torque

3

PERMANENTLY LEGIBLE

- Scaling and lettering clearly marked and very easy to read thanks to good contrast

4

IMPROVED READABILITY

- The optimized double scale, the coloring and the central alignment of the main scale and the vernier ensure that the setting values are easy to read

5

INTUITIVE, ERGONOMIC APPLICATION

- The hand is centered in the middle of the handle thanks to the ergonomic shape of the handle.
- Clearly audible and tactile torque release



"The Torcofix can be adjusted very precisely and works great. I used it to overhaul an engine and am completely satisfied."

TF-SE
TORQUE WRENCH
TORCOFIX TF-SE
 5-400 Nm / 3,7-300 lbf·ft

from

€116,⁸¹
 + VAT



- > For controlled right- and left-hand tightening (insert tool for change of direction)
- > Controlled screw tightening in the most common range of 5 - 400 Nm / 3,7 - 300 lbf·ft (guide for screws M7-10.9 to M20-6.9)
- > Adjustable, releasing and sturdy tubular torque wrench with rectangular cavity for industry and the trades
- > Classified as per DIN EN ISO 6789-2:2017 Type II Class A; adjusted to a maximum permissible +/-3% deviation and thus with a greater precision than the standard-stipulated +/-4%
- > Incl. traceable test certificate (DIN EN ISO 6789-2:2017)
- > Rectangular holder incl. ejector aid in 9x12 mm and 14x18 mm versions
- > Robust, matt powder-coated tubular steel construction, with galvanized ratchet and high-quality plastic parts
- > New ergonomic handle, shaped according to the natural grip position of the hand

- > Clearly recognisable and tactile hand centring aid and calibration aid in the middle of the handle
- > Double scale Nm / lbf·ft and vernier are protected from abrasion and contamination by an enlarged viewing window
- > With vernier scale for Nm main scale for setting intermediate scale values; lbf·ft setting only via main scale
- > Vertical alignment of the scale, torque adjustment therefore suitable for left and right handers
- > Scale line positioned directly above the scale prevents reading errors (parallax errors)
- > Unit labeling integrated in the scale frame and also protected by viewing windows,
- > Precise jump-off mechanism generates a clearly perceptible and audible trigger signal when the set torque value is reached
- > Incl. roll away protection, prevents rolling away when the tool is put down



Code	No.	Drive connector rectangular	Nm	lbf·ft	Scale division nm	vernier nm	Total length mm	Calibration length	Depth gauge mm	Weight kg	excl. VAT
3288196	TF-SE25	9 x 12 mm	5-25	3,7-18	1	0,1	261,5	261,5	17,5	0.3	116,81
3288218	TF-SE50	9 x 12 mm	10-50	7,5-37	2,5	0,25	291,5	236,5	17,5	0.35	125,21
3278522	TF-SE100	9 x 12 mm	20-100	15-75	5	0,5	378	310,3	17,5	0.77	134,45
3278530	TF-SE150	9 x 12 mm	30-150	22-110	10	1	469	401,3	17,5	0.93	152,94
3278549	TF-SE200	14 x 18 mm	40-200	30-150	10	1	479	411,3	25,0	1.01	161,34
3278557	TF-SE300	14 x 18 mm	60-300	45-220	10	1	570	502,3	25,0	1.19	179,83
3278565	TF-SE400	14 x 18 mm	80-400	60-300	10	1	657	589,3	25,0	1.62	269,75

7412
RECTANGULAR
REVERSIBLE
RATCHET
HEAD
9x12



- > For solving difficult assembly problems
- > SE recording 9x12
- > 1/4" to 30 Nm continuous load capacity
- > 3/8" to 135 Nm continuous load capacity
- > 1/2" to 150 Nm continuous load capacity

Code	No.	Drive connector square	Drive connector square mm	Return angle	Head height mm	Width of head mm	Depth gauge	Permanent load capacity	Weight kg	excl. VAT
7672710	7412-00	1/4"	6,3	5	16,6	25	17,5	1/4" = 30 Nm	0.06	63,27
7686500	7412-01	3/8"	10	5	23,2	34	17,5	3/8" = 135 Nm	0.14	70,50
7687230	7412-02	1/2"	12,5	5	24,2	34	17,5	1/2" = 150 Nm	0.15	72,26

7418
RECTANGULAR
REVERSIBLE
RATCHET
HEAD
14x18



- > For solving difficult assembly problems
- > SE recording 14x18
- > 1/2" to 340 Nm continuous load capacity
- > 3/4" to 400 Nm continuous load capacity

Code	No.	Drive connector square	Drive connector square mm	Return angle	Head height mm	Depth gauge	Permanent load capacity	Weight kg	excl. VAT
7687580	7418-02	1/2"	12,5	7,2	28,8	25,0	1/2" = 340 Nm	0.363	72,26
7687660	7418-04	3/4"	20	7,2	35,5	33,0	3/4" = 400 Nm	0.79	90,67

SUKSE
RECTANGULAR
RING RATCHET
SPANNER
reversible 9x12



- > UD profile, fine toothed
- > Switch lever for right/left rotation
- > To operate with a 9x12 mm torque wrench or rectangular handle 9x12 mm

Code	No.	Width across flats mm	Return angle	Head height mm	Width of head mm	Depth gauge	Weight kg	excl. VAT
2827735	SUKSE9 10	10	7°	7,7	21	40,0	0.07	54,19
2827743	SUKSE9 13	13	7°	9	25,7	42,0	0.09	55,12
2827751	SUKSE9 17	17	6°	10,6	33,6	45,0	0.13	56,97
2827778	SUKSE9 19	19	6°	11,7	36,3	52,0	0.15	57,81

AGSE9
PLUG-IN PICK-UP HANDLE SE
9x12

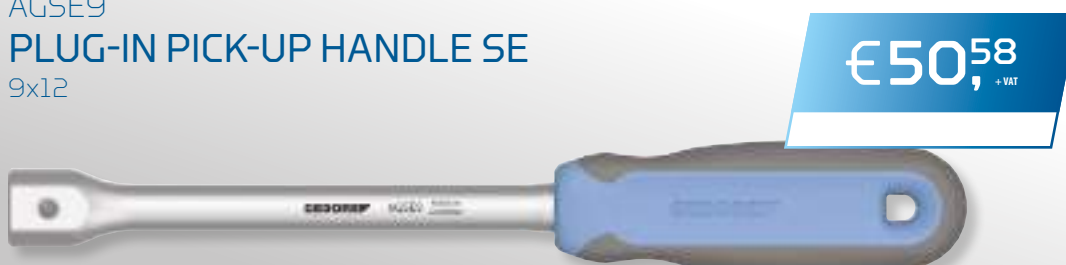

- > For insertion tools 9x12
- > Without torque function
- > Max. continuous load 150 Nm

Code	No.	Length mm	Height mm	Width mm	Weight kg
2827786	AGSE9	267	18,5	22	0.32

8563-N-05

TORQUE WRENCH DREMOMETER DNR SET 3/4"

155-760 Nm

€1083,¹⁹
+ VAT



- › Torque wrench 155-760 Nm tightening range with test certificate; with extension tube
- › Controlled clockwise tightening; 3/4" output drive; plus clockwise rotating 3/4" add-on ratchet
- › Error-free operation due to length independence
- › Classified as per DIN EN ISO 6789-2:2017; adjusted to a maximum permissible +/-3% deviation and thus with a greater precision than the standard-stipulated +/-4%
- › Vernier scale - resolution 1.0 Nm

3/4"



Code	No.	Type	Square drive inch	Square drive metric mm	Contents	Nm	Height mm	Housing - square centre spacing mm	Length mm	Weight kg
3107043	8563-N-05	Single square	3/4"	40	DREMOMETER DN 3/4" with vernier 155-760 Nm No. 8563-N-00 Extension tube DR/DX ALU no. 8571-80 Ratchet no. 754-04	155-760	35	22,5	812	3.005

8581-01

TORQUE WRENCH WITH DREMOMETER EK

600-1500 Nm



€1444,⁵⁴
+ VAT

- › Torque wrench with 1" square drive 600 - 1500 N-m range
- › Single and double square for controlled right and left tightening
- › Audible and perceptible, automatic short-path triggering
- › Single scale for measuring range in Nm
- › Highest accuracy max. deviation of +/- 3 %
- › Error-free operation - no value shift when actuated outside the handle
- › Certificate according to DIN EN ISO 6789:2017 Part 2
- › Energy-saving due to the use of an extension tube

1"



Code	No.	Type	Square drive inch	Square drive metric mm	Contents	Nm	Height mm	Housing - square centre spacing mm	Length mm	Head width mm	Head height mm	Weight kg
2311267	8581-01	Single square	1"	25	Extension tube 8564-92	600-1500	71	30	932	60,0	40	10.8

754-06

RATCHET HEAD DREMOMETER

€351,²⁶
+ VAT



- › Enables controlled torque tightening in combination with a DREMOMETER torque wrench
- › With 1" square drive
- › Made of chrome-vanadium steel
- › Max. Continuous load capacity of connecting square according to DIN EN ISO 6789-2017 or max. load of the receptacle

1" 1"

Code	No.	Drive mount, square inch	Drive square inch	Head height mm	Head Ø mm	Return angle	Use	Version/ Execution	Continuous load	Weight kg
7680810	754-06	1"	1"	62	73	10°	E / EK	Clockwise	1" = 2000 N-m	1.8

CL
**ELECTRONIC TEST
 DEVICE CAPTURE LITE**
 0,25-350 Nm / 0,19-260 lbf-ft



- › Digital torque tester for testing torque wrenches and torque screwdrivers
- › Light yet robust due to aluminium housing
- › 3 models in the range from 0,25 Nm to 350 Nm
- › With 1/4", 3/8", 1/2" square mount
- › Measuring tolerance +/- 1 % for all readings
- › 3 measuring modes: floating value display (track), kink point detection (first peak), peak value measurement (peak)
- › Simple & Easy operation due to 1-button operation (measuring mode, unit)
- › Switchable between Nm, lbf-ft and lbf-in
- › Optimal readability due to single-line illuminated OLED display
- › Autostart function when a torque tool is inserted
- › Auto-sleep mode when not in use
- › Power supply and data output via USB connection

€990,76
 + VAT



Code	No.	Nm	lbf-ft	Drive connector hexagon female mm	Drive connector square female mm	Drive connector square female "	Adapter inch	Weight kg	excl. VAT
3119319	CL 10	0,25-10	0,19-7,4	6,3	6,3	1/4"	1/4"	1.42	990,76
3297896	CL 10 S	0,25-10	0,19-7,4		6,3	1/4"		1.42	990,76
3297926	CL 350	10-350	7,4-260		12,5	1/2"	3/8"	1.65	990,76

DVV-13Z
**TORQUE MULTIPLIER
 DREMOPLUS ALU**
 1300 Nm / 950 lbf-ft

- › Controlled screw tightening and loosening
- › With single-stage planetary gear
- › High-performance aluminium housing
- › Better than +/- 3 % accuracy
- › To operate with a suitable torque wrench
- › Optionally retrofittable with straight reaction arm L-shaped
- › Model with transmission ratio 1:5



from
€990,76
 + VAT



Code	No.	Output torque (max.) Nm	Output torque (max.) lbf-ft	Multiplication ratio	Version reaction arm	Drive connector square inch	Output square	Weight kg	excl. VAT
2653370	DVV-13Z	1300	950	1:5	Z-Form, cranked	1/2"	3/4"	1.3	990,76
2653389	DVV-13ZG	1300	950	1:5	Z-Form, cranked	1/2"	3/4"	3	1041,18

DVI-20 / DVI-28
TORQUE MULTIPLIER
DREMOPLUS ALU
 2000-2800 Nm / 1500-2050 lbf-ft

- › Industry, construction sites, commercial vehicle and car workshops, agricultural technology, construction machinery
- › Bridge, ship, aircraft and railway construction, refineries
- › Output square with hole for Impact sockets with locking pin and ring



from **€1173,¹¹** + VAT



Code	No.	Output torque (max.) Nm	Output torque (max.) lbf-ft	Multiplication ratio	Version reaction arm	Output square	Weight kg	excl. VAT
2653265	DVI-20Z	2000	1500	1:4	Z-Form, cranked	1"	1.8	1173,11
2653249	DVI-20L	2000	1500	1:4	L-Form, straight	1"	1.8	1626,05
2653273	DVI-28Z	2800	2050	1:5,5	Z-Form, cranked	1"	2.4	1259,66
2653257	DVI-28L	2800	2050	1:5,5	L-Form, straight	1"	2.4	1713,45

TSN
TORQUE WRENCH
TSN SLIPPER
 5-25 Nm / 44-221 lbf-in / Fixed setting

- › Fixed adjustable torque spanner for series assembly
- › 1/4" and 3/8" square drive with integrated ratchet function
- › For controlled right-hand tightening
- › Overtightening of the screw is not possible
- › Certificate according to DIN EN ISO 6789, +/- 4 % tolerance
- › Fixed setting at GEDORE or by hand on a testing device
- › If fixed setting at the factory is desired is required, please state the Nm value when ordering (price on request)
- › EPA (Electrostatic Protected Area) compliant
- › Ratchet with slip-through function - even safer in series assembly



€251,²⁶ + VAT



Code	No.	Type	Square drive inch	Square drive metric mm	Nm	Length mm	Weight kg	excl. VAT
7091900	TSN 25 D	Single square ratchet	1/4"	6,3	5-25	216	0.34	251,26
7092040	TSN 25 A	Single square ratchet	3/8"	10	5-25	216	0.34	251,26

SIMPLE OPERATION



PRO 450 FH TORQUE SCREWDRIVER TYPE PRO FH

0.5 - 13.5 Nm / fixed setting

€71,42
+ VAT



- › Pre set torque screwdriver for series assembly
- › 1/4" hexagon socket for 1/4" bits - C 6.3
- › With adaptor also suitable for 1/4" square drive sockets as per DIN 3124
- › Error proof torque application
- › Test certificate according to DIN EN ISO 6789, permissible deviation of +/- 6 %.
- › Precision mechanism slides through clearly noticeable and audible (CLICK and slip) when the set value is reached - overtightening is not possible
- › Automatic resetting to the starting position
- › Fatigue-free work due to ergonomic handle
- › Lightweight, but robust and corrosion-resistant construction design

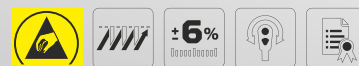

Code	No.	Drive mount inch	Drive mount metric mm	Nm	Total length mm	Weight kg	excl. VAT
2927772	PRO 450 FH	1/4"	6,3	0,5-4,5	140	0.23	71,42
2927780	PRO 1350 FH	1/4"	6,3	2,5-13,5	140	0.23	71,42

QSN TORQUE SCREWDRIVER TYPE QSN

0,08 - 9 Nm

from

€225,21
+ VAT



- › Adjustable torque screwdriver - with scale
- › 1/4" hexagon socket for 1/4" bits - C 6.3
- › With adaptor also suitable for 1/4" square drive sockets as per DIN 3124
- › Error proof torque application
- › Test certificate acc. to DIN EN ISO 6789
- › Lightweight, but robust and corrosion-resistant construction design
- › Models No. QSN600 FH QSN900 FH additional cross handle



Code	No.	Drive mount inch	Drive mount metric mm	Nm	Total length mm	Weight kg	excl. VAT
1498738	QSN 40 FH	1/4"	6,3	0,08-0,4	159	0.124	233,61
1400150	QSN 120 FH	1/4"	6,3	0,2-1,2	183	0.23	225,21
1400169	QSN 600 FH	1/4"	6,3	1-6	196	0.335	225,21
1400177	QSN 900 FH	1/4"	6,3	4-9	196	0.335	226,05

TT3KH
ELECTRONIC TORQUE WRENCH
TORCOTRONIC III
 10-350 Nm / 7,4-258,2 lbf·ft

from **€814,²⁹** + VAT

- › Microprocessor-controlled, electronic torque wrench
- › Torque and torque angle measure
- › Documented right and left suit
- › Software included
- › 5 parameters storable
- › 2000 storage places
- › Measurement accuracy torque +/- 1 %, +/- 1 digit
- › Measurement accuracy torque angle +/- 1 %, but min. +/- 1° on 360° with min. 4°/sec
- › Different depth gauges for end fittings programmable
- › Simple operation, user-friendly icon menu navigation
- › Clearly readable, illuminated LCD display
- › Factory certificate according to DIN ISO 6789
- › Optional certificate according to DAKKS-DKD-R 3-7



Code	No.	Type	Square drive inch	Square drive metric mm	Nm	Length mm	Weight kg	excl. VAT
2648636	TT3KH 120	Rectangular cavity	1/2"	12,5	10-120	670	1.2	814,29
2648644	TT3KH 350	Rectangular cavity	1/2"	12,5	70-350	900	1.74	990,76

763
TORQUE WRENCH
DREMOMETER T-FS
 pre-set, 5-12 Nm

€143,⁷⁰ + VAT

- › Easy application for torques that are usually in the range of torque screwdrivers
- › For controlled directional tightening
- › Certificate according to DIN EN ISO 6789:2017 Part 2
- › Special ranges are available on request



Code	No.	Type	Square drive inch	Square drive metric mm	Fixed setting value	Weight kg	excl. VAT
1947958	763-05	Single square rigid	1/4"	6,3	5 N·m	0.241	143,70
1947966	763-06	Single square rigid	1/4"	6,3	6 N·m	0.545	143,70
1947974	763-07	Single square rigid	1/4"	6,3	7 N·m	0.241	143,70
1947990	763-08	Single square rigid	1/4"	6,3	8 N·m	0.241	143,70
1948008	763-09	Single square rigid	1/4"	6,3	9 N·m	0.241	143,70
1948016	763-10	Single square rigid	1/4"	6,3	10 N·m	0.241	143,70
1948032	763-12	Single square rigid	1/4"	6,3	12 N·m	0.241	143,70

SK 2154 PH-06

3C-SCREWDRIVER SET WITH STRIKING CAP

6 pieces



- › For firmly seated slotted and cross-head screws PH
- › With an additional hexagon drive on the hexagonal blade and striking cap
- › Ergonomic 3-component Power-Grip³ handle for maximum power transmission with minimum strain on the hand
- › With hanging hole on the handle for space-saving storage

€31,67
+ VAT



Code	No.	Contents
1878743	SK 2154 PH-06	2154SK 4,5 5,5 6,5 8 mm, 2160SK PH 1 2 mm

Pieces	Weight kg
6	0.88

2150-2160 PH 3C-SCREWDRIVER SET



from

€18,98
+ VAT

- › Practical set composition in environmentally-friendly cardboard box
- › For slotted and cross-head screws PH
- › Ergonomic 3-component Power-Grip³ handle for maximum power transmission with minimum strain on the hand
- › With hanging hole on the handle for space-saving storage
- › Type of drive marked at end of the handle



Code	No.	Contents
1482319	2150-2160 PH-06	3K screwdriver bit slot no. 2150 SW 4 5.5 6.5 8mm 3K screwdriver Phillips No. 2160 PH 1 2
1482343	2150-2160 PH-010	3K screwdriver bit slot no. 2150 3 4 5.5 6.5 8 3K screwdriver bit, slotted, short, no. 2153 5.5 3K screwdriver Phillips No. 2160 PH 1 2 3K screwdriver Phillips, short no. 2161 PH1 Live Checker 3.5

Pieces	Weight kg	excl. VAT
6	0.66	18,98
10	0.825	35,29

2163 TX-010
3C-SCREWDRIVER SET
 10 pieces



- > Perfect All-rounder for working in wood, plastic and metal for internal TX screws
- > Type of drive marked at end of the handle
- > Ergonomic handle shape for precise, fatigue-free work
- > Positive connection of handle and blade for optimum power transmission
- > High-quality and durable thanks to tempered blades made from GEDORE molybdenum-vanadium steel

€63,²⁷
 + VAT



Code	No.	Contents
1482335	2163 TX-010	2163 TXT 7 8 9 10 15 20 25 30 27 40

Pieces	Weight kg
10	0.74

DT 2142-008
**HEXAGON SOCKET
 KEY SET**
 8 pieces

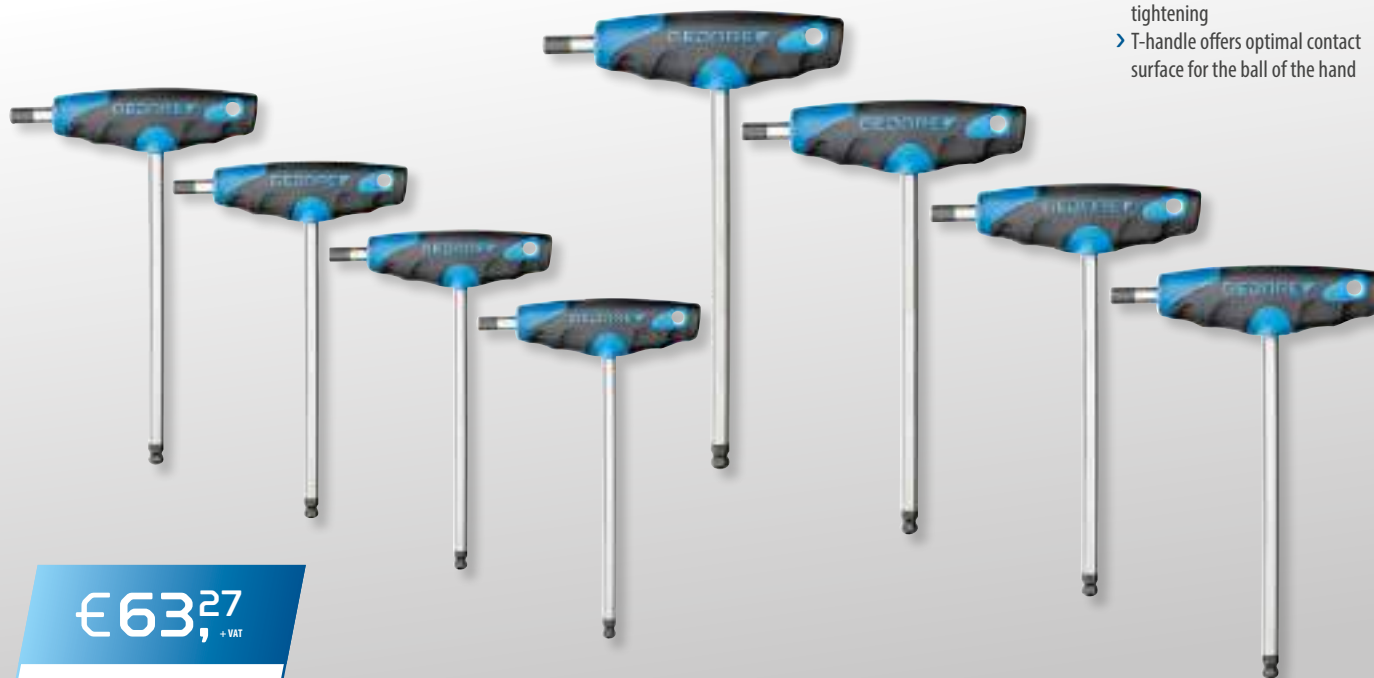

- > For in-hex screws
- > With two hexagons, same size each end
- > Long blade with ball end
- > 2-component T-handle for high torque when loosening or tightening
- > T-handle offers optimal contact surface for the ball of the hand

€63,²⁷
 + VAT



Code	No.	Contents
3037371	DT 2142-008	Hexagon allen key with 2CT-handle No. DT 2142, 2 2.5 3 4 5 6 8 10 mm

Length mm	Width mm	Height mm	Pieces	Weight kg
325	320	45	8	0.97

DT 2143 KTX-007
**HEXAGON
 SOCKET KEY
 SET TX**
 7 pieces



- › With ball end, working angle approx. 25°
- › 2-component T-handle for high torque when loosening or tightening
- › T-handle offers optimal contact surface for the ball of the hand

€98,³²
 + VAT



Code	No.	Contents	Length mm	Width mm	Height mm	Pieces	Weight kg
3037398	DT 2143 KTX-007	Hexagon socket key with 2CT-handle No. DT 2143 KTX T10 T15 T20 T25 T27 T30 T40	325	320	45	7	0.71

H 42 CKEL-09
HEXAGON SOCKET KEY SET
 colour coded, 9 pieces



- › For loosening and tightening hexagon socket screws
- › Ball head enables screwing in places that are difficult to access
- › Colour coding makes it easy to choose the correct key
- › Key easily removable
- › Abrasion-resistant powder-coated

€32,⁵¹
 + VAT

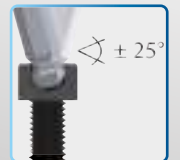

Code	No.	Contents	Length mm	Width mm	Height mm	Pieces	Weight kg
3297470	H 42 CKEL-09	42 CKEL 1,5 2 2,5 3 4 5 6 8 10	120	85	20	9	0.415

H 43 KTX-07
**HEXAGON SOCKET
 KEY SET**
 for recessed
 TX head screws,
 7 pieces



- › For loosening and tightening Torx screws
- › Key easily removable
- › Ball head allows you to work in hard-to-reach places
- › Burnished chrome vanadium steel (50CrV4)

€66,⁸⁸
 + VAT



Code	No.	Contents	Pieces	Weight kg
1531441	H 43 KTX-07	43 KTX T10 T15 T20 T25 T27 T30 T40	7	0.169

WSL-L7
**TOOL TROLLEY
 WORKSTER
 SMARTLINE**
 with 7 drawers



€721,85
 + VAT



- › Working platform with cover made of ABS plastic with front flattening and anti-roll edge, as well as small additional storage compartments
- › Side panels with Euro perforation 10 x 38 mm
- › Lateral roundings - minimization of butt edges
- › Individual drawer stopping stops more than one drawer being opened, one-handed operation
- › 7 wide drawers (W 640x D 400 mm) fully extending
- › Load capacity per drawer 20 kg
- › Total load capacity 400 kg



Code	No.	RAL	Height mm	Width mm	Depth mm	Drawers	Max. load-bearing capacity kg	Number of drawers	Crosswise divider	Lengthwise divider	Weight kg
2977311	WSL-L7	GEDORE blue, RAL 5017	1.045	505	870	5x Type 1, H = 80 mm 2x Type 2, H = 162,5 mm	400	7	optionally available	optionally available	85

WSL-L-TS-147
**TOOL TROLLEY WORKSTER
 SMARTLINE WITH TOOL
 ASSORTMENT IN CT MODULES**
 147 pieces



€1352,10
 + VAT

- › Perfect tool combination in check tool modules for industry, trade and the automotive sector
- › GEDORE Check-Tool-System: 2-colour foam insert to check that the set is complete
- › Non-slip, with recessed grip
- › Resistant to oil and grease
- › Tools in metric sizes
- › In tool trolley No. WSL-L7
- › Lateral rounding - minimization of abutting edges

Detailed listing of the range contents from page 60 onwards



Code	No.	Contents	Width mm	Height mm	Depth mm	Pieces	Weight kg
2980312	WSL-L-TS-147	1/4"+1/2" socket wrench assortment in CT module no. TS CT2-D19-D20, 81 pcs Combination wrench set in CT module no. TS CT2-7, 24 pcs Tool assortment in CT module no. TS CT2-2154SK-119, 14 pcs Pliers assortment in CT module no. TS CT2-142, 28 pcs + tool trolley workster smartline no. WSL-L7	870	1.045	505	147	97

WSL-L-TS-308
TOOL TROLLEY WORKSTER
 with 308-piece tool assortment

- > Perfect tool combination in check tool modules for industry, trade and the automotive sector
- > Tools in metric sizes
- > Non-slip, with recessed grip
- > Resistant to oil and grease
- > Tools in metric sizes
- > In tool trolley No. WSL-L7
- > Lateral rounding - minimization of abutting edges

Detailed listing of the range contents from page 60 onwards

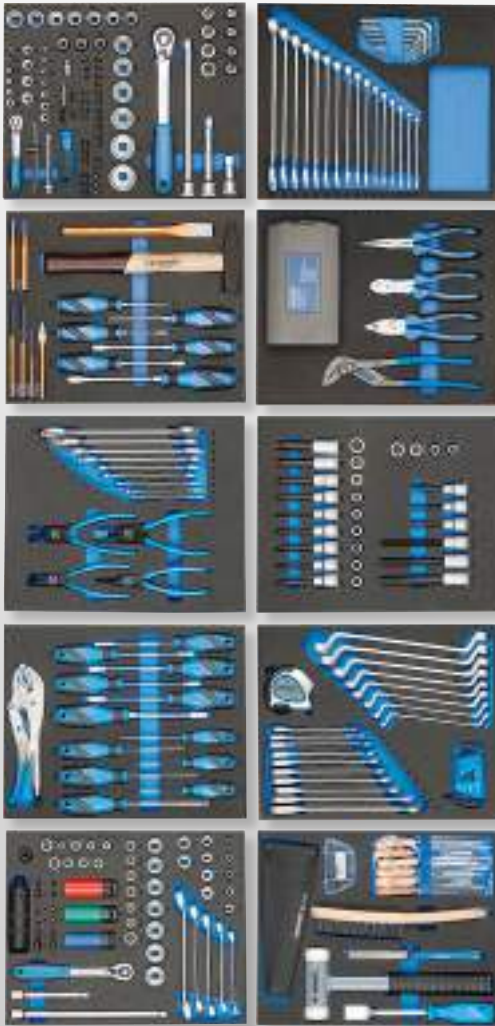

€2763,⁸⁷ + VAT



Code	No.	Contents	Width mm	Height mm	Depth mm	Pieces	Weight kg
2980347	WSL-L-TS-308	1/4"+1/2" socket wrench assortment in CT module no. TS CT2-D19-D20, 81 pcs Combination wrench set in CT module no. TS CT2-7, 24 pcs Tool assortment in CT module no. TS CT2-2154SK-119, 14 pcs Pliers assortment in CT module no. TS CT2-142, 28 pcs Tool assortment in 2/4 CT module no. TS CT2-6-8000, 15 pcs 1/2" set of screwdriver bits in 2/4 CT module No. TS CT2-ITX19, 28 pcs Tool assortment in 2/4 CT module no. TS CT2-2133-2163TX, 13 pcs Wrench set in 2/4 CT module no. TS CT2-7R-2, 28 pcs Tool assortment in 2/4 CT module no. TS CT2-D30, 59 pcs Tool assortment in 2/4 CT module no. TS CT2-710, 17 pcs Hacksaw no. 407 + tool trolley workster smartline no. WSL-L7	870	1.045	505	308	105.6

WSL-M6
TOOL TROLLEY
WORKSTER
SMARTLINE
 with 6 drawers

€541,¹⁸
 + VAT



- > Working platform with cover in ABS plastic with front flattening and anti-roll edge
- > Side panels with Euro perforation 10 x 38 mm
- > Lateral roundings - minimization of butt edges
- > Individual drawer stopping stops more than one drawer being opened, one-handed operation
- > Central locking with cylinder lock
- > 6 wide drawers (W 480 x D 400 mm) fully extending
- > Load capacity per drawer 20 kg
- > Total load capacity 300 kg



Code	No.	RAL	Height mm	Width mm	Depth mm	Drawers	Max. load-bearing capacity kg	Number of drawers	Weight kg
3100707	WSL-M6	GEDORE blue, RAL 5017	900	625	510	5x Type 1, H = 80 mm 1x Type 2, H = 160 mm	300	6	48

WSL-M-TS-172
TOOL TROLLEY
WORKSTER
 with tool set 172 pieces



€1175,⁶³
 + VAT

- > For safe, orderly and mobile storage of tools and equipment
- > Perfect tool combination in check tool modules for industry, trade and the automotive sector
- > Working platform with cover in ABS plastic with front flattening and anti-roll edge
- > Non-slip, with recessed grip
- > Resistant to oil and grease
- > Tools in metric sizes
- > In tool trolley No. WSL-M6

Detailed listing of the range contents on page 132



Code	No.	Contents	Width mm	Height mm	Depth mm	Pieces	Weight kg
3100197	WSL-M-TS-172	Combination wrench no. 1 B, SW 8 10 11 12 13 14 15 16 17 18 19 21 22 24 27 30 32 mm Socket wrench insert no. C19 SW 8 10 11 12 13 14 15 16 17 18 19 20 21 22 24 27 30 32mm 1/2" screwdriver socket hexagon No. IN19, SW 5 6 7 8 9 10 12 14 17 19 mm 1/2" reversible ratchet No. 1993 U-10 T, 1/2" extension No. 1990, 75 125 250 mm 1/2" extension No.1990 M, with holding magnet Bit socket box with ratchet 1/4" 35 pieces, No. 666-U-20, Torsion bit set no. 666-042 1/4" ratchet screwdriver SilentGEAR No. 2675 with bit holder Allen key no. H 42-10, hexagon SW 1.3 1.5 2.2 5 3 4 5 6 8 10 mm 3K screwdriver no. 2150, 4 5.5 6.5 8mm, 3K screwdriver no. 2160 PH 1 2 Universal pliers no. 142 10TL, 10", Multiple pliers no. 8133-200JC, 200mm Power side cutters no. 8316-180JC, 180mm, Voltage tester slot no. 4615 3, 220-250V, 3mm Machinist's hammer no. 4 E-500, 500g Twist drill set no. 8550-024, Ø 1 1.5 2 2.5 3 3.5 4 4.5 5 5.5 6 6.5 7 7.5 8 8.5 9 9.5 10 10.5 mm	625	900	510	172	76.9

WHL-L7 TOOL TROLLEY WORKSTER

with 7 drawers



€898,³²
+ VAT

- › Work platform with PP plastic cover with front flattening and roll protection edge, as well as small additional storage compartments, can and screwdriver holder
- › Stainless steel insert in top
- › Side panels with Euro perforation 10 x 38 mm
- › Sides rounded off – minimising abutting edges
- › Individual drawer stopping stops more than one drawer being opened, one-handed operation
- › Central locking with cylinder lock and security key
- › 5 flat, wide drawers (W 640 x D 400) with full extension
- › 2 high, wide drawers (W 640 x D 400) with full extension
- › Load capacity per drawer 40 kg
- › Total load capacity 500 kg



Code	No.	RAL	Height mm	Width mm	Depth mm	Drawers	Max. load-bearing capacity kg	Number of drawers	Weight kg
3033708	WHL-L7	GEDORE blue, RAL 5017	1.045	785	510	5x Type 1, H = 80 mm 2x Type 2, H = 160 mm	500	7	84

WHL-L7-TS-147 TOOL TROLLEY WORKSTER

147 pieces



- › Tool set in check tool modules (CT) for industry, trade and the automotive sector
- › Completeness check through 2-coloured foam inserts
- › Non-slip, with recessed grip
- › Resistant to oils and greases
- › Tools in metric sizes
- › In tool trolley No. WHL-L7

Detailed listing of the range contents from page 60 onwards

€1629,⁴¹
+ VAT

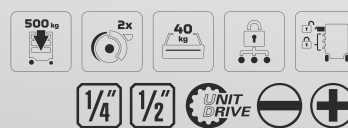

Code	No.	Height mm	Width mm	Depth mm	Contents	Drawers	Number of drawers	Pieces	Weight kg
3082105	WHL-L7-TS-147	1.045	785	510	1/4" + 1/2" socket wrench assortment in CT module no. TS CT2-D19-D20, 81 pcs Combination wrench set in CT module no. TS CT2-7, 24 pcs Tool assortment in CT module no. TS CT2-2154SK-119, 14 pcs Pliers assortment in CT module no. TS CT2-142, 28 pcs + tool trolley workster highline no. WHL-L7	7 drawers: 5x Type 1, H = 80 mm 2x Type 2, H = 160 mm	7	147	97

WHL-L7- TS-308 TROLLEY WORKSTER HIGHLINE WITH TOOL ASSORTMENT

308 pieces

- > Tool set in check tool modules (CT) for industry, trade and the automotive sector
- > Completeness check through 2-coloured foam inserts
- > Non-slip, with recessed grip
- > Resistant to oils and greases
- > Tools in metric sizes
- > In tool trolley No. WHL-L7

Detailed listing of the range contents from page 60 onwards



€2805,88 + VAT

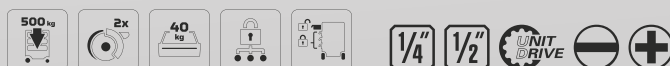

Code	No.	Height mm	Width mm	Depth mm	Contents	Drawers	Number of drawers	Pieces	Weight kg
3082113	WHL-L7-TS-308	1.045	785	510	1/4"+1/2" socket wrench assortment in CT module no. TS CT2-D19-D20, 81 pcs Combination wrench set in CT module no. TS CT2-7, 24 pcs Tool assortment in CT module no. TS CT2-2154SK-119, 14 pcs Pliers assortment in CT module no. TS CT2-142, 28 pcs Tool assortment in 2/4 CT module no. TS CT2-6-8000, 15 pcs 1/2" set of screwdriver bits in 2/4 CT module No. TS CT2-ITX19, 28 pcs Tool assortment in 2/4 CT module no. TS CT2-2133-2163TX, 13 pcs Wrench set in 2/4 CT module no. TS CT2-7R-2, 28 pcs Tool assortment in 2/4 CT module no. TS CT2-D30, 59 pcs Tool assortment in 2/4 CT module no. TS CT2-710, 17 pcs Hacksaw no. 407 + tool trolley workster highline no. WHL-L7	7 drawers: 5x Type 1, H = 80 mm 2x Type 2, H = 160 mm	7	308	112.6

HEAVY DUTY TOOL TROLLEY

The workshop trolley is unparalleled on the market.

The **GEDORE tool trolley 2004 0620** has a torsion-resistant body made of sheet steel, which is corrosion-resistant and scratch-resistant and powder-coated, and has a total load capacity of 1 ton. Up to a load of 750 kg, it is Easy to manoeuvre and mobile. The 2004 workshop trolley has been transformed from a mobile storage solution into a mobile workshop thanks to the three new lid variants, with a stainless steel, wooden or plastic plate available. The drawers offer sufficient storage space for tools and, with the ball-bearing guide rails, ensure smooth full extension even with heavy loads.



Tool trolley 2004 0620

1

HIGH OVERALL LOAD CAPACITY

- Secure stationary and mobile storage of all necessary tools without affecting the product properties of the trolley

2

SMOOTH RUNNING, MANEUVERABILITY AND DIRECTIONAL STABILITY

- Easy to steer, even under maximum load

3

HIGH LOAD CAPACITY OF THE DRAWERS

- The combination of total load capacity and ball-bearing guide rails allows a high loading of each individual drawer

4

EVEN MORE FLEXIBILITY

- 3 new lid variants turn the mobile storage solution into a mobile workshop



THE ORIGINAL SETS
THE STANDARDS
FOR SAFETY

„The 2004 tool trolley from GEDORE is highly resilient and impresses in every respect!“

2004 0620
TOOL
TROLLEY

€1133,⁶¹
+ VAT



- > ABS worktop with small part compartments
- > Storage compartment with perforated sheet (Euro perforation 10 x 38 mm), two removable drawers for small parts and door on the handle side
- > Added safety due to heel and edge protection
- > Central locking with cylinder lock
- > Wide drawers (W 480 x D 400 mm) fully extendable, removable
- > Total load capacity 1000 kg static (750 kg dynamic)

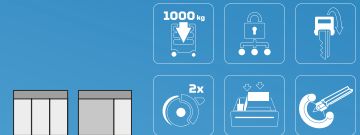

Code	No.	RAL	Height mm	Width mm	Depth mm	Drawers	Max. load-bearing capacity kg	Number of drawers	Crosswise divider	Lengthwise divider	Weight kg
1640720	2004 0620	GEDORE blue, RAL 5017	1.020	865	605	6x Type 1, H = 67 mm 2x Type 2, H = 137 mm	1000	8	2	3	88

1500 ES-02-2004
TOOL TROLLEY WITH
TOOL ASSORTMENT

207 pieces

€2167,²³
+ VAT



- > High-performance tool trolley in proven GEDORE industrial quality with basic equipment for the commercial sector or the ambitious do-it-yourselfer
- > Heel protection edging and impact protection ensure safety
- > Tools in metric sizes
- > Proven GEDORE ES tool modules in ABS plastic
- > Resistant to oils and greases
- > In tool trolley No. 2004 0620

Detailed listing of the range contents from page 62 onwards

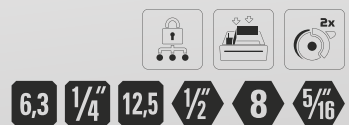

Code	No.	Contents	Width mm	Height mm	Depth mm	Pieces	Weight kg
2657708	1500 ES-02-2004	Combination wrench set in 2/3 ES module no. 1500 ES-1B Double open-end wrench set in 1/3 ES module no. 1500 ES-6 1/2" set of sockets in 1/3 ES module No. 1500 ES-19 IS 1/2" set of screwdriver bits in 1/3 ES module No. 1500 ES-ITX 19 LKP 1/2" set of screwdriver bits in 1/3 ES module No. 1500 ES-IN 19 LKM 1/2" accessory for socket wrench inserts in 1/3 ES module No. 1500 ES-1993 U-20 1/4" socket wrench assortment in 1/3 ES module No. 1500 ES-20 Socket wrench set in 1/3 ES module no. 1500 ES-2133 Set of open-end wrenches with ring ratchet in 1/3 ES module no. 1500 ES-7R Pliers assortment in 1/3 ES module no. 1500 ES-145 Chisel assortment in 1/3 ES module no. 1500 ES-350 Measuring range in 1/3 ES module no. 1500 ES-711 Screwdriver set in 1/3 ES module no. 1500ES-2150PH 1/2" screw remover assortment in 1/3 ES module No. 1500 ES-K 1900 Assembly pliers set in 1/3 ES module no. 1500 ES-8000 Spacer module empty No.1500 ED-70 K, 475x77x40 mm [6x] + Tool trolley with 8 drawers no. 2004 0620	865	1.020	605	207	117.1

1500 ES-03-2004
TOOL TROLLEY
WITH TOOL ASSORTMENT
 325 pieces

- › High-performance tool trolley in proven GEDORE industrial quality with extensive industrial range for professionals
- › Heel protection edging and impact protection ensure safety
- › Tools in metric sizes
- › Proven GEDORE ES tool modules in ABS plastic
- › In tool trolley No. 2004 0810

Detailed listing of the range contents from page 62 onwards



€2982,³⁵ + VAT

6,3 1/4 12,5 1/2
 6,3 1/4 8 5/16

Code	No.	Contents	Width mm	Height mm	Depth mm	Pieces	Weight kg
2657716	1500 ES-03-2004	Puller set in 1/3 ES module No. 1500 ES-107 Combination spanner set in 2/3 ES module No. 1500 ES-1 B Double box spanner set in 1/3 ES module No. 1500 ES-2 1/2" Socket set in 1/3 ES module No. 1500 ES-19 IS 1/2" Accessories for sockets in 1/3 ES module No. 1500 ES-1993 U-20 1/4" Socket set in 1/3 ES module No. 1500 ES-20 1/4" Socket set in CT module No. 1500 CTD-20 BIT Socket spanner set in 1/3 ES module No. 1500 ES-2133 Screwdriver set in 1/3 ES module No. 1500 ES-2150 PH Screwdriver set in 1/3 ES module No. 1500 ES-2163 TX Double-ended spanner set in 1/3 ES module No. 1500 ES-34 Chisel assortment in 1/3 ES module No. 1500 ES-350 Double-ended ring spanner set in 1/3 ES module No. 1500 ES-400, open Double open-end spanner set in 1/3 ES module No. 1500 ES-6 Combination ratchet spanner set in 1/3 ES module No. 1500 ES-7 R Measuring set in 1/3 ES module No. 1500 ES-711 Set of assembly pliers in 1/3 ES module No. 1500 ES-8000 Offset screwdriver set in 2/3 ES module No. 1500 ES-DT 2142 1/2" Set of hexagonal screwdriver bits in 1/3 ES module No. 1500 ES-IN 19 LKM 1/2" Set of screwdriver bits in 1/3 ES module No. 1500 ES-ITX 19 LKP 1/2" Screwdriver assortment in 1/3 ES module No. 1500 ES-K 1900 VDE pliers assortment in 1/3 ES module No. 1500 ES-VDE 145 VDE Screwdriver set in 1/3 ES module No. 1500 ES-VDE 2170 PZ Screw extractor set No. 8551-55, M3-M18 Offset screwdriver set No. H 42 KEL-88, hexagonal 2 2.5 3 4 5 6 8 10 mm, ball end Offset screwdriver set TX No. H 43 KTX-07, TX T10 T15 T20 T25 T27 T30 T40 Key file set No. 8728 Flat butt, 3-edge, 4-edge, half-round, round file Adjustable open-end spanner No. 60 P 8 10" Grip pliers No. 137 10 Voltage tester slot No. 4615 3, 220-250 V, 3mm Cable knife No. 0513-09, 195 mm Scraper No. 133 K Spacer module empty No. 1500 ED-70 K, 475x77x40 mm [7x] + Tool trolley with 9 drawers No. 2004 0810	865	1.020	605	325	125.8

2005 0810 TOOL TROLLEY

€1175,⁶³
+ VAT



- › ABS worktop with compartments for small parts
- › Side panels with Euro perforation 10 x 38 mm
- › Added safety due to heel protection and edge protection
- › Central locking with cylinder lock
- › Wide drawers (W 640 x D 400 mm) fully extendable, removable
- › Load capacity per drawer 40 kg, bottom heavy-duty drawer 60 kg
- › Total load capacity 1000 kg static (750 kg dynamic)

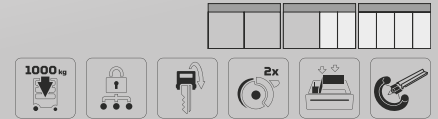

Code	No.	RAL	Height mm	Width mm	Depth mm	Drawers	Max. load-bearing capacity kg	Number of drawers	Crosswise divider	Lengthwise divider	Weight kg
2003562	2005 0810	GEDORE blue, RAL 5017	1.020	865	605	8x Type 1, H = 67 mm 1x Type 2, H = 137 mm	1000	9	2	3	93

2005 HP WOOD PLATE

€54,¹⁹
+ VAT



- › To be inserted into the plastic lid to obtain a flat working surface
- › Made of multiplex beech plywood
- › Suitable for tool trolleys 2004 and 2005 and tool chest 2430
- › No. 2004 HP until year of construction 03/2014 for depth 435 mm, No. 2004 HP-14 from year of construction 04/2014, for depth 475 mm
- › No. 2005 HP from year of construction 04/2022, for depth 440mm

NEW

Code	No.	Length mm	Depth mm	Width mm	Weight kg
3419320	2005 HP	440	30	615	4.5

411-125 PARALLEL VICE

€197,⁴⁸
+ VAT



- › Sturdy forged design
- › Protected vice spindle
- › Adjustable guidance

Code	No.	Jaw width mm	Usable clamping reach mm	Weight kg
6501100	411-125	125	150	12.4

2005 EP STAINLESS STEEL PLATE

€98,³²
+ VAT



- › Insert for the plastic cover of the tool trolley no. 2004 and 2005 as well as tool chest no. 2430
- › Made of stainless steel
- › Easy to remove and clean

NEW

Code	No.	Depth mm	Width mm	Weight kg
3419339	2005 EP	1	610	2.201

2430 TOOL CHEST

€541,¹⁸
+ VAT



- › Sheet steel, corrosion resistant and scratch-proof powder-coated, GEDORE blue
- › Tough ABS worktop, with 3 compartments for small parts
- › Central locking with cylinder lock
- › Wide drawers (W 640 x D 400 x H 67 mm) fully extendable, removable
- › Each drawer with safety locking, single-hand operation
- › Load capacity per drawer 40 kg



Code	No.	Height mm	Width mm	Depth mm	Lengthwise divider	Crosswise divider	Weight kg
1888927	2430	345	775	475	3	2	34

RT 2004 L REAR PANEL BOARD

€133,⁶¹
+ VAT

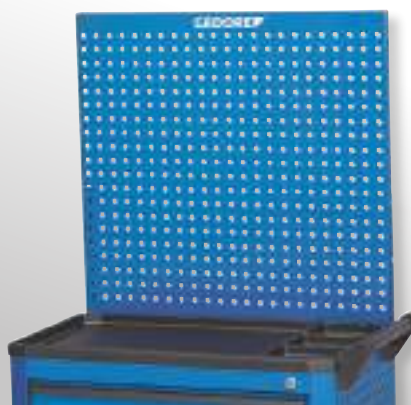

- › Can be attached to 2004 and 2005 (as well as retro fit to models 2002 and 2003)
- › Square perforation 10 x 38 mm for tool hooks and holders No. 1500 H

Code	No.	Height mm	Width mm	Depth mm	Weight kg
2663104	RT 2004 L	715	765	30	11

2005-TS-147 TOOL TROLLEY WITH TOOL ASSORTMENT

147 pieces

€1621,⁰¹
+ VAT



- › Metric tool sizes
- › In Check-Tool-Modules
- › In tool trolley No. 2005 0511

Detailed listing of the range contents from page 60 onwards

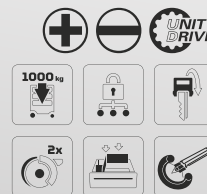

Code	No.	Contents	Width mm	Height mm	Depth mm	Pieces	Weight kg
2980282	2005-TS-147	TS CT2-D19-D20 1/4"+1/2" socket wrench assortment 81 pcs TS CT2-7 combination wrench set 24 pcs TS CT2-2154SK-119 tool set 14 pcs TS CT2-142 Pliers Assortment 28 pcs + 2005 0511 tool trolley with 7 drawers	865	1.020	605	147	104.3

2005-TS-190 TOOL TROLLEY WITH TOOL ASSORTMENT

190 pieces

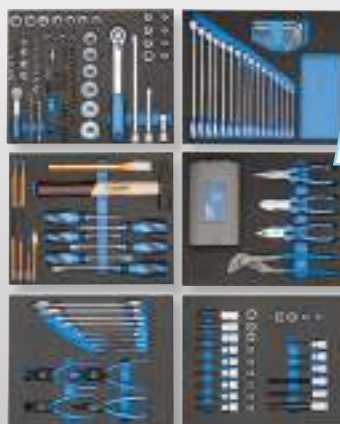

€1889,⁹²
+ VAT

- > Tools in metric sizes
- > In Check-Tool-Modules
- > In tool trolley No. 2005 0511

Detailed listing of the range contents from page 60 onwards

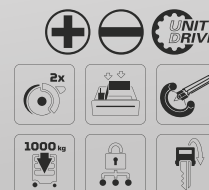

Code	No.	Contents	Width mm	Height mm	Depth mm	Pieces	Weight kg
2980290	2005-TS-190	1/4"+1/2" socket wrench assortment in CT module no. TS CT2-D19-D20, 81 pcs Combination wrench set in CT module no. TS CT2-7, 24 pcs Tool assortment in CT module no. TS CT2-2154SK-119, 14 pcs Pliers assortment in CT module no. TS CT2-142, 28 pcs Tool assortment in 2/4 CT module no. TS CT2-6-8000, 15 pcs 1/2" set of screwdriver bits in 2/4 CT module No. TS CT2-ITX19, 28 pcs + Tool trolley with 7 drawers no. 2005 0511	865	1.020	605	190	109.6

2005-TS-308 TOOL TROLLEY WITH TOOL ASSORTMENT

308 pieces



€2982,³⁵
+ VAT

- > Tools in metric sizes
- > In Check-Tool-Modules
- > In tool trolley No. 2005 0511

Detailed listing of the range contents from page 60 onwards

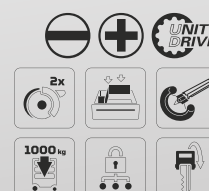

Code	No.	Contents	Width mm	Height mm	Depth mm	Pieces	Weight kg
2980304	2005-TS-308	1/4"+1/2" socket wrench assortment in CT module no. TS CT2-D19-D20, 81 pcs Combination wrench set in CT module no. TS CT2-7, 24 pcs Tool assortment in CT module no. TS CT2-2154SK-119, 14 pcs Pliers assortment in CT module no. TS CT2-142, 28 pcs Tool assortment in 2/4 CT module no. TS CT2-6-8000, 15 pcs 1/2" set of screwdriver bits in 2/4 CT module No. TS CT2-ITX19, 28 pcs Tool assortment in 2/4 CT module no. TS CT2-2133-2163TX, 13 pcs Wrench set in 2/4 CT module no. TS CT2-7R-2, 28 pcs Tool assortment in 2/4 CT module no. TS CT2-D30, 59 pcs Tool assortment in 2/4 CT module no. TS CT2-710, 17 pcs Hacksaw no. 407 + Tool trolley with 7 drawers no. 2005 0511	865	1.020	605	308	121.6

WORKSHOP TROLLEY 2005 XL WITH 25% MORE SPACE

Not much more needs to be said about the **GEDORE** 2005 tool trolley – unless the classic comes in a new XL version. All the advantages and properties of the mobile workstation combined with 25 percent more volume, which is distributed across extra-wide drawers.

The **GEDORE tool trolley 2005 XL 0330** is the solution when the mobility and maneuverability of a workshop trolley and the large storage space of a workbench are required. At 792 mm, the drawers of the 2005 XL are a full 17 cm wider than those of the standard model: an increase in drawer volume of 25%. The load – a maximum of 1,000 kg in static operation, 750 kg in mobile operation – is easily carried by the drawers running on ball-bearing guide rails and the chassis with trapezoidal axle construction. Even under full load, the 2005 XL retains its manoeuvrability, smooth running and directional stability.



Tool trolley 2005 XL 0330

1

SMOOTH RUNNING, MANEUVERABILITY AND DIRECTIONAL STABILITY

- Easy to move, even under maximum load

2

HIGH OVERALL LOAD CAPACITY

- Secure stationary and mobile storage of all necessary tools without affecting the product properties of the trolley

3

HIGH LOAD CAPACITY OF THE DRAWERS

- The combination of total load capacity and ball-bearing guide rails allows a high loading of each individual drawer up to 60 kg

4

LARGE STORAGE SPACE

- Extra wide drawers ensure plenty of storage space



*EVEN WIDER,
EVEN BIGGER*

"I don't have to make any compromises with the 2005 XL 0330 tool trolley from GEDORE. Enough space for all tools and super flexible!"

2005 XL WORKSHOP TROLLEY



Body:

- > Storage tray made of ABS plastic with compartment for small parts
- > Manoeuvrable and easy to control with the driving and steering handle
- > Side panels with Euro perforation 10 x 38 mm for attaching hooks and tools
- > Edge protection to minimize the damage of impacts
- > Sheet steel, corrosion-resistant and scratch-resistant powder-coated, GEDORE blue

drawers:

- > Central locking with cylinder lock
- > Wide drawers (W 792 x D 400 mm) with full extension, removable
- > Safety lock for each drawer, one-handed operation
- > Ball bearing guide rails
- > Can be individually equipped with longitudinal and transverse dividers (also available individually)
- > Load capacity per drawer 60 kg, lower heavy-duty drawer 70 kg
- > Total load capacity 1000 kg static (750 kg dynamic)
- > 2 roller-bearing GEDORE high-performance wheels (fixed castors Ø 200 mm)
- > 2 ball-bearing mounted GEDORE smooth-running wheels (swivel castors Ø 125 mm), both with total brakes
- > Even under maximum loads, the GEDORE axle design ensures: smooth running, maneuverability and directional stability
- > Longitudinal (LT) and transverse dividers (QT) made of galvanized sheet steel (also available individually)
- > Can be optimally equipped with GEDORE tool modules (No. 1500 ES/1500 CT or 2005 CT)
- > Special colors and designs on request

Available from March 1st, 2023

from

€1259,66
+ VAT

Code	No.	RAL	Height mm	Width mm	Depth mm	Drawers	Max. load-bearing capacity kg	Number of drawers	Crosswise divider	Lengthwise divider	Weight kg	excl. VAT
3437515	2005 XL 0221	GEDORE blue, RAL 5017	1.020	1.021	605	2x Type 1, H=71mm 2x Type 2, H=146mm 1x Type 3, H=221mm	1000	5	2	3	92	1259,66
3437523	2005 XL 0330	GEDORE blue, RAL 5017	1.020	1.021	605	3x Type 1, H=71mm 3x Type 2, H=146mm	1000	6	2	3	97	1310,08

LARGE STORAGE

TTB 0321
TOOL TROLLEY
 with 6 drawers

- › Compact tool trolley with 6 drawers and plenty of storage space
- › The total load capacity is 900 kg (static) and 650 kg (dynamic).
- › Wide drawers (W 640 x D 400 mm) with central locking and cylinder lock
- › Thanks to ball-bearing guide rails with full telescopic extension, the entire drawer can be accessed
- › Two heavy-duty wheels with roller bearings and two light-duty wheels with ball bearings and total locking device



€811,76
 + VAT

Code	No.	Height mm	Width mm	Depth mm	Drawers	Max. load-bearing capacity kg	Number of drawers	Weight kg
3411435	TTB 0321	985	775	475	3x Type1, H. = 67 mm 2x Type2, H. = 137 mm 1x Type3, H. = 207 mm	900	6	78

TTB-TS-173
**TOOL TROLLEY
 WITH ASSORTMENT**

173 pieces



- > Compact tool trolley with versatile tool set, as basic equipment for the workshop
- > The total load capacity is 900 kg (static) and 650 kg (dynamic).
- > Intelligent product selection from which the torsion bit set, a 1/4" bit socket box and multiple pliers stand out
- > The torsion bit set with torsion bits, sockets and much more for demanding and diverse screw connections.
- > Bit socket wrench box including the premium quality ratchet with a low swing-back angle of 6° for hard-to-reach places
- > The multiple pliers are perfect for holding, bending, cutting, stripping, crimping and squeezing

Detailed listing of the range contents on page 133

€1259,⁶⁶
 + VAT



Code	No.	Height mm	Width mm	Depth mm	Contents	Drawers	Pieces	Weight kg
3411443	TTB-TS-173	985	775	475	Tool assortment in CT inserts no. TS-173, 173 pcs + Tool trolley with 6 drawers no. TTB 0321	3x Typ1, H. = 67 mm 2x Typ2, H. = 137 mm 1x Typ3, H. = 207 mm	173	90.7

VDE TOOLS FOR ELECTRIC AND HYBRID VEHICLES IN THE WORKSHOP TROLLEY

The complete solution for vehicle mechatronics specialists specializing in electric and hybrid vehicles: 103 hand tools and special tools for the automotive sector with protective insulation, housed in a specially marked workshop trolley.

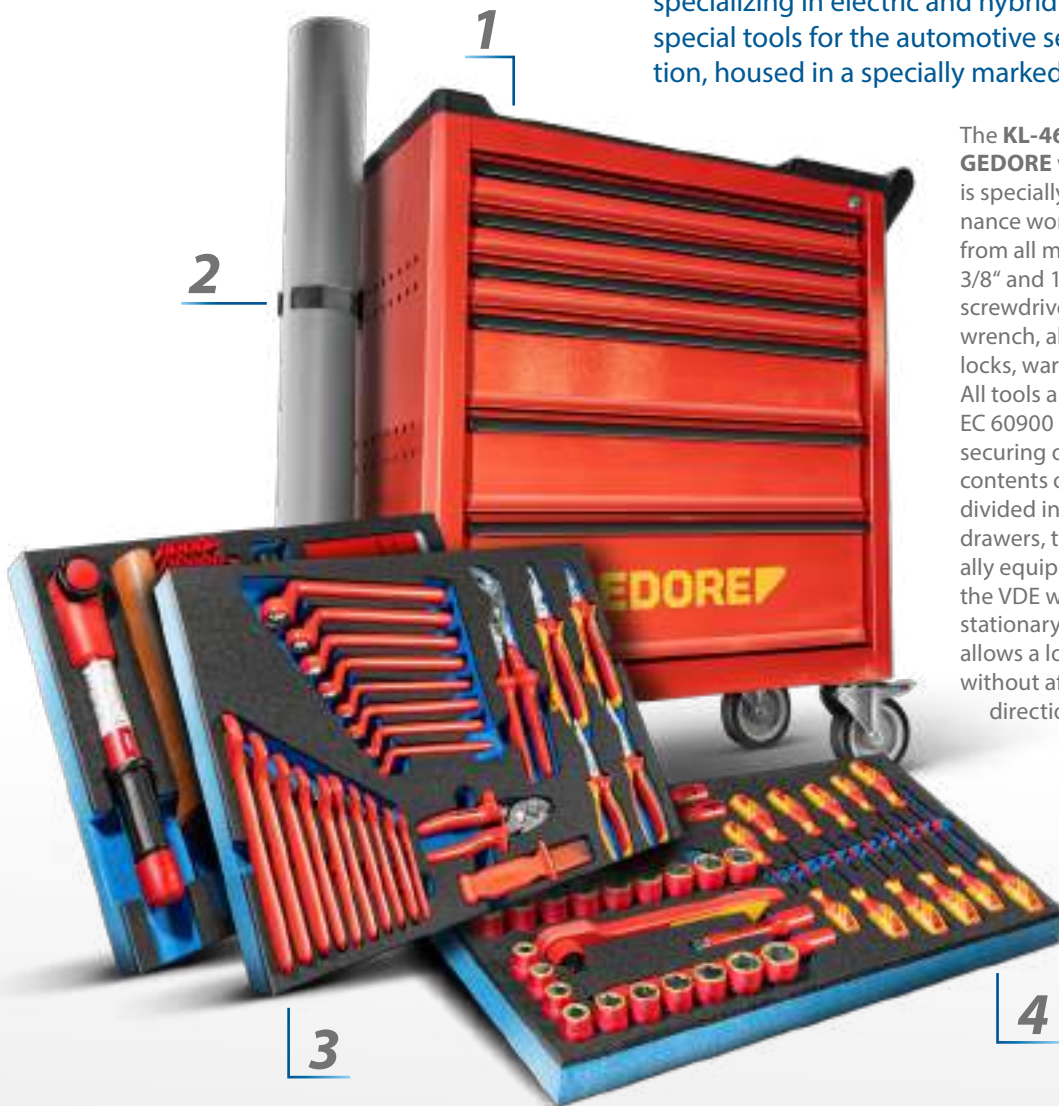

The **KL-4600-200 VDE** workshop trolley from **GEDORE** with its 103-part VDE range, which is specially designed for repair and maintenance work on hybrid and electric vehicles from all manufacturers, contains complete 3/8" and 1/2" socket wrench sets and pliers, screwdrivers, spanners and a VDE torque wrench, also digital voltage testers, safety locks, warning signs and other accessories. All tools are insulated according to EN60900 / EC 60900 and designed for the professional securing of hybrid and electric vehicles. The contents of the workshop trolley are sensibly divided into foam inserts on three of the six drawers, three more drawers can be individually equipped. The high total load capacity of the VDE workshop trolley of 900 kg in stationary and 650 kg in mobile operation allows a lot of leeway when equipping without affecting the maneuverability and directional stability of the trolley.

VDE Tool trolley KL-4600-200

1

RESILIENT, MOBILE WORK BASE

- Total load capacity 900 kg, 6 drawers can be loaded up to 40 kg and high-performance chassis

2

SPECIAL TOOL TROLLEY

- Red special paint indicates the exclusive purpose of the trolley, including holder for ISO floor mat

3

TOOL FOR AUTOMOTIVE MECHATRONICS

- Hand and special tools such as digital voltage testers, safety locks, warning signs and much more. In top quality

4

ELECTRIC AND HYBRID VEHICLES FROM ALL MANUFACTURERS

- Complete tool kit with protective insulation according to EN 60900 / EC 60900

„The range is perfect for EV work and I have a workstation just for that purpose with the eye-catching red trolley.“

KL-4600-200
**TOOL TROLLEY WITH
 HIGH-VOLTAGE ASSORTMENT**
 103 pieces

- > With its unique kit assembly, the high-voltage VDE tool trolley is ideal for working on hybrid and electric vehicles safely
- > Perfect for repair and maintenance work on vehicles of all manufacturers.
- > All tools are insulated with protection according to EN 60900/EC 60900.
- > The tool trolley has side panels with Euro perforations, a heavy-duty chassis with external bearings, ball-bearing guide rails, and central locking.



€3880,00
 + VAT

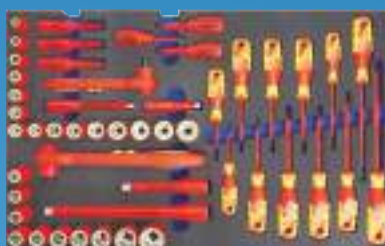

Code	No.	Height mm	Width mm	Depth mm	Drawers	Static load carrying capacity kg	Load capacity kg	Number of drawers	Pieces	Weight kg
3415740	KL-4600-200	985	775	475	Full-extension runner	900	650	6	103	96

Contents

- 3/8" VDE tool assortment with SW 6 - 22; XZN M8 - M12
- 3/8" VDE torque wrench 5 - 25 Nm
- 1/2" VDE tool assortment with SW 10 - 24; IN 5 - 8 mm;
- VDE open-end wrench SW 9 - 24
- VDE ring spanner SW 8 - 22
- VDE slotted screwdriver; Phillips; TX T8 - T30
- VDE cable shears
- VDE universal pliers
- VDE power combination pliers
- VDE power side cutters
- VDE needle nose pliers, angled
- VDE flat nose pliers
- VDE cable knife
- meter spouts
- Digital voltage tester 1,000 V
- Electrician protective gloves
- liner gloves
- Rubber drape 250 x 350 mm
- ISO standing mat
- barrier tape
- „Lightning“ warning sign
- High-voltage warning sign „Switched on“
- High-voltage warning sign „Switched off“
- safety lock
- plastic clip 80 mm; 160mm
- Cable spreader
- rubber mallet

1504 0511
MOBILE WORKBENCH



€1534,45
+ VAT

- > Sheet steel, corrosion resistant and scratch-proof powder-coated, GEDORE blue
- > 30 mm thick multiplex beech wood worktop, surface additionally protected by linseed oil varnish
- > Large usable storage space with shelf and door
- > Safety through heel protection
- > Central locking with cylinder lock
- > Wide drawers (W 480 x D 400 mm) fully extendable, removable
- > Load capacity per drawer 40 kg, bottom heavy-duty drawer 60 kg
- > GEDORE high-performance running gear, total load capacity 1000 kg, in mobile operation 750 kg
- > The GEDORE trapezoidal axle construction secures smooth running, manoeuvrability and track-keeping also in case of maximum loads



Code	No.	Height mm	Width mm	Depth mm	Worktop thickness mm	Drawers	Number of drawers	Weight kg
6622830	1504 0511	985	1.100	630	30	5x Type 1, H = 67 mm 1x Type 2, H = 137 mm 1x Type 3, H = 207 mm	7	102

BR 1504 0511 LH
MOBILE
WORKBENCH



- > Sheet steel, corrosion resistant and scratch-proof powder-coated, GEDORE blue
- > 30 mm thick multiplex beech wood worktop, surface protected by linseed oil varnish
- > Large usable storage space with shelf and door
- > Central locking with cylinder lock
- > Safety through heel protection for persons
- > Load capacity per drawer 40 kg, bottom heavy-duty drawer 60 kg
- > GEDORE high-performance running gear, total load capacity 1000 kg, in mobile operation 750 kg
- > The GEDORE trapezoidal axle construction secures smooth running, manoeuvrability and track-keeping also in case of maximum loads

€2217,65
+ VAT



Code	No.	Height mm	Width mm	Depth mm	Worktop thickness mm	Drawers	Number of drawers	Weight kg
6623990	BR 1504 0511 LH	1.625	1.100	665	30	5x Type 1, H = 67 mm 1x Type 2, H = 137 mm 1x Type 3, H = 207 mm	7	130

1504 XL 1710
MOBILE WORKBENCH
EXTRA-WIDE
 with 7 drawers

€1713,⁴⁵
 + VAT



- › Sheet steel, corrosion resistant and scratch-proof powder-coated, GEDORE blue
- › 30 mm thick multiplex beech wood worktop, surface protected by linseed oil varnish
- › Large usable storage space with shelf and door
- › Safety through heel protection for persons
- › Central locking with cylinder lock
- › 1 XL drawer (W 1055 x D 400), 6 wide drawers (W 640 x D 400 mm) fully extendable, removable
- › Each drawer with safety locking, single-hand operation
- › Ball-bearing guide rails
- › Can be individually equipped with lengthwise and crosswise dividers (can be ordered individually)
- › Load capacity per drawer 40 kg, bottom heavy-duty drawer 60 kg

- › Can be optimally equipped with GEDORE tool modules (No. 1500 ES/1500 CT or 2005 CT)
- › Total load capacity 1000 kg, 750 kg when mobile
- › 2 roller-bearing GEDORE high-performance wheels (fixed castors Ø 200 mm)
- › 2 ball-bearing mounted GEDORE smooth-running wheels (swivel castors Ø 125 mm), both with total brakes
- › The GEDORE trapezoidal axle construction secures smooth running, manoeuvrability and track-keeping also in case of maximum loads
- › 10 length- (LT) and 2 crosswise (QT) dividers from zinc-plated sheet steel
- › Rear panel R 1504 XL-L can be added
- › Further drawer combinations on request
- › Special colors on request
- › Delivery without tools and accessories

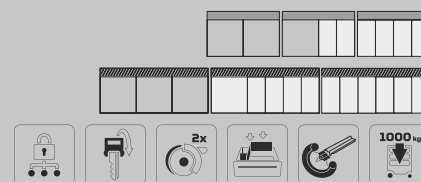

Code	No.	Height mm	Width mm	Depth mm	Worktop thickness mm	Drawers	Number of drawers	Weight kg
2259001	1504 XL 1710	985	1.250	630	30	1x Type 1, H. = 75 mm extra wide 7x type 2, H. = 67 mm 1x Type 3, H. = 137 mm	9	126.5

1505 MOBILE WORKBENCH

€2074,79
+ VAT



- › Sheet steel, corrosion resistant and scratch-proof powder-coated, GEDORE blue
- › 40 mm thick multiplex beech plywood board, surface additionally protected by linseed oil varnish
- › Easy, safe movement with pull handle
- › Safety for persons due to heel protection
- › Central locking with cylinder lock, simultaneous locking of drawers and door
- › 5 wide drawers (W 480 x D 550 mm) with partial extension (505 mm), removable
- › Ball-bearing guide rails
- › Can be individually equipped with lengthwise and crosswise dividers (can be ordered individually)
- › Load capacity per drawer 40 kg
- › Total load capacity 2000 kg, 500 kg when mobile
- › Absolutely stable standing when lowered
- › High floor clearance
- › Can be equipped with GEDORE tool modules (1500 ES/1500 CT)
- › Rear panel no. R 1504 L can be added
- › Delivery without tools and accessories



Code	No.	Height mm	Width mm	Depth mm	Worktop thickness mm	Drawer	Number of drawers	Weight kg
6621780	1505	900	1.100	650	40	3x Type 1, H = 79 mm 1x Type 2, H = 160 mm 1x Type 3, H = 180 mm	5	139

1506 XL 2511 MOBILE WORKBENCH EXTRA-WIDE

€1713,45
+ VAT



- › For safer orderly and mobile storage of tools and equipment
- › 30 mm thick multiplex beech wood worktop, surface protected by linseed oil varnish
- › Safety for persons due to heel protection
- › Central locking with cylinder lock per drawer unit, keyed alike
- › Wide drawers (W 480 x D 400 mm) fully extendable, removable
- › Ball-bearing guide rails
- › Load capacity per drawer 40 kg, bottom heavy-duty drawer 60 kg
- › Total load capacity 1000 kg, 750 kg when mobile
- › The GEDORE trapezoidal axle construction secures smooth running, manoeuvrability and track-keeping also in case of maximum loads
- › 4 distance modules No. 1500 ED-70 K
- › Length- (LT) and crosswise (QT) dividers from zinc-plated sheet steel (can be ordered individually)
- › Can be equipped with GEDORE tool modules (1500 ES/1500 CT)
- › Rear panel R 1504 XL-L can be added
- › Different locks on request



Code	No.	Height mm	Width mm	Depth mm	Worktop thickness mm	Drawers	Number of drawers	Weight kg
2528088	1506 XL 2511	985	1.250	630	30	10x Type 1, H = 67 mm 2x Type 2, H = 137 mm 2x Type 3, H = 207 mm	14	141

BR 1500 LH WORKBENCH WITH TOOL CABINET

- > Sheet steel, corrosion resistant and scratch-proof powder-coated, GEDORE blue
- > 40 mm thick multiplex beech plywood board, surface protected by linseed oil varnish
- > Large storage space with shutter
- > Safety through heel protection
- > Shutter with cylinder lock
- > Rear panel with square perforation 10 x 38 mm
- > Separate central locking of drawers and shutter with cylinder locks
- > Load capacity per drawer 40 kg
- > Total load capacity (workbench) 2000 kg

€3696,⁶⁴
+ VAT



Code	No.	RAL	Height mm	Width mm	Depth mm	Drawers	Max. load-bearing capacity kg	Number of drawers	Shelves	Crosswise divider	Lengthwise divider	Worktop thickness mm	Weight kg
6618210	BR 1500 LH	GEDORE blue	1.790	2.000	875	3x Type 1, H = 79 mm 1x Type 2, H = 160 mm 1x Type 3, H = 180 mm	2000	5	1	2	3	40	203.73

1500 H 25-8 SPRAY CAN HOLDER

for 8 spray cans

€49,⁷⁴
+ VAT



- > Compatible with standard Euro square perforation 10 x 38 mm
- > Can also be used as transport box due to removable dividers
- > powder-coated
- > With carrying handle
- > Front square perforation for additional hooks (not included)
- > Delivery without tools and accessories

Code	No.	Width mm	Height mm	Depth mm	Weight kg
3127907	1500 H 25-8	315	100	165	2.05

1500 H 40 PAPER ROLL HOLDER

€31,⁶⁷
+ VAT



- > For paper rolls up to diameter 320 mm and width 320 mm
- > Lateral perforation for additional hooks (not included in delivery)
- > Made of sheet steel
- > Colour RAL 9005 black
- > Suitable for all tool trolleys/benches with Euro perforation 10 x 38 mm
- > Delivery without tools and accessories

Code	No.	Width mm	Depth mm	Weight kg
2997754	1500 H 40	350	200 mm	1.1

S 1500 ES-01

MODULE ASSORTMENT SMALL

104 pieces



- General basic assortment for beginners of all professions
- Tools in metric sizes
- GEDORE ES tool modules in ABS plastic

€881,⁵¹_{+ VAT}

6,3 1/4" 12,5 1/2"

Code	No.	Contents	Pieces	Weight kg
2319845	S 1500 ES-01	Combination wrench set in 2/3 ES module no. 1500 ES-1B 1/2" set of socket wrench inserts in 1/3 ES module No. 1500 ES-19, hexagon 1/2" accessory for socket wrench inserts in 1/3 ES module No. 1500 ES-1993 U-20 1/4" socket wrench assortment in 1/3 ES module No. 1500 ES-20 Pliers assortment in 1/3 ES module no. 1500 ES-145 Chisel assortment in 1/3 ES module no. 1500 ES-350 Screwdriver set in 1/3 ES module no. 1500ES-2150PH	104	14.02

S 1500 ES-02

MODULE ASSORTMENT MIDDLE

207 pieces



- Basic equipment for the commercial sector or ambitious do-it-yourselfers
- Tools in metric sizes
- GEDORE ES tool modules in ABS plastic
- Suitable for mounting in GEDORE tool trolley No. WSL-L7 (workster)
- For workbench No. 1504 Variant 0701, 0810, 1000, No. 1506 XL Variant 2511 and 2810

€1805,⁸⁸_{+ VAT}

6,3 1/4" 12,5 1/2" 8 5/16"

Code	No.	Contents	Pieces	Weight kg
2319853	S 1500 ES-02	Combination wrench set in 2/3 ES module no. 1500 ES-1B Double open-end wrench set in 1/3 ES module no. 1500 ES-6 1/2" set of sockets in 1/3 ES module No. 1500 ES-19 IS 1/2" set of screwdriver bits in 1/3 ES module No. 1500 ES-ITX 19 LKP 1/2" set of screwdriver bits in 1/3 ES module No. 1500 ES-IN 19 LKM 1/2" accessory for socket wrench inserts in 1/3 ES module No. 1500 ES-1993 U-20 1/4" socket wrench assortment in 1/3 ES module No. 1500 ES-20 Socket wrench set in 1/3 ES module no. 1500 ES-2133 Set of open-end wrenches with ring ratchet in 1/3 ES module no. 1500 ES-7R Pliers assortment in 1/3 ES module no. 1500 ES-145 Chisel assortment in 1/3 ES module no. 1500 ES-350 Measuring range in 1/3 ES module no. 1500 ES-711 Screwdriver set in 1/3 ES module no. 1500 ES-2150 PH 1/2" Screw remover assortment in 1/3 ES module no. 1500 ES-K 1900 Assembly pliers set in 1/3 ES module no. 1500 ES-8000 Spacer module empty No.1500 ED-70 K, 475x77x40 mm [6x]	207	28.3

S 1500 ES-03 MODULE ASSORTMENT LARGE

325 pieces



- › Extensive industrial range for professionals
- › Tools in metric sizes
- › GEDORE ES tool modules in ABS plastic
- › For tool trolley no. 2005 variant 0810, no. 2004 variant 0810, 1000
- › For workbench No. 1504 Version 0810, 1000, No. 1504 XL, No. 1506 XL Version 2511, 2810, No. 1507 XL
- › Also available in tool trolley No. 2004 0810

€2483,¹⁹
+ VAT



Code	No.	Contents	Pieces	Weight kg
2319861	S 1500 ES-03	Puller set in 1/3 ES module No. 1500 ES-1.07 Combination spanner set in 2/3 ES module No. 1500 ES-1 B Double box spanner set in 1/3 ES module No. 1500 ES-2, 1/2" Socket set in 1/3 ES module No. 1500 ES-19 IS 1/2" Accessories for sockets in 1/3 ES module No. 1500 ES-1993 U-20 1/4" Socket set in 1/3 ES module No. 1500 ES-20 1/4" Socket set in CT module No. 1500 CTD-20 BIT Socket spanner set in 1/3 ES module No. 1500 ES-2133 Screwdriver set in 1/3 ES module No. 1500 ES-2150 PH Screwdriver set in 1/3 ES module No. 1500 ES-2163 TX Double-ended spanner set in 1/3 ES module No. 1500 ES-34 Chisel set in 1/3 ES module No. 1500 ES-350 Double box spanner set in 1/3 ES module No. 1500 ES-400, open Double open-end spanner set in 1/3 ES module No. 1500 ES-6 Combination ratchet spanner set in 1/3 ES module No. 1500 ES-7 R Measuring set in 1/3 ES module No. 1500 ES-711 Set of assembly pliers in 1/3 ES module No. 1500 ES-8000 Offset screwdriver set in 2/3 ES module No. 1500 ES-DT 2142 1/2" Set of screwdriver bits in 1/3 ES module No. 1500 ES-IN 19 LKM 1/2" Set of screwdriver bits in 1/3 ES module No. 1500 ES-ITX 19 LKP 1/2" Screwdriver assortment in 1/3 ES module No. 1500 ES-K 1900 VDE pliers assortment in 1/3 ES module, No. 1500 ES-VDE 145 VDE Screwdriver set in 1/3 ES module No. 1500 ES-VDE 2170 PZ Screw extractor set No. 8551-55, M3-M18 Offset screwdriver set No. H 42 KEL-88, 2.2.5 3 4 5 6 8 10 mm, ball end Offset screwdriver set No. H 43 KTX-07, TX T10 T15 T20 T25 T27 T30 T40 Key file set No. 8728 Flat butt, triangular, square, half-round, round file Adjustable spanner No. 60 P 8 10", Grip pliers No. 137 10, Voltage tester No. 4615 3, 220-250 V, 3mm Cable knife No. 0513-09, 195 mm, Scraper No. 133 K Spacer module empty No. 1500 ED-70 K, 475x77x40 mm [7x]	325	38

TS-147 TOOL ASSORTMENT

in check tool modules, 147 pieces

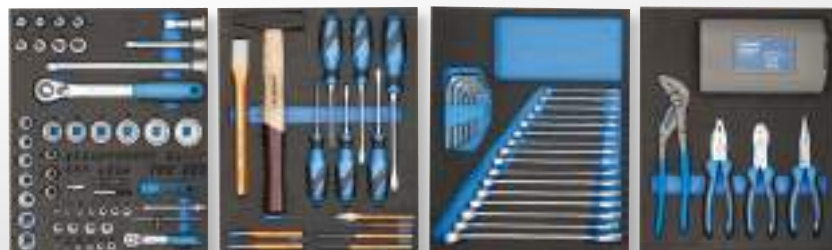

- › Tools in metric sizes
- › GEDORE Check-Tool-System: 2-colour foam insert to check that the set is complete
- › Each tool is securely held in its own pocket, grip recesses facilitate removal of the tools
- › Resistant to oil and grease

€839,⁵⁰
+ VAT



Code	No.	Contents	Pieces	Weight kg
2955997	TS-147	1/4"+1/2" socket wrench assortment in CT module no. TS CT2-D19-D20, 81 pcs Combination wrench set in CT module no. TS CT2-7, 24 pcs Tool assortment in CT module no. TS CT2-2154SK-119, 14 pcs Pliers assortment in CT module no. TS CT2-142, 28 pcs	147	11.98

TS-190

TOOL ASSORTMENT

in check tool modules, 190 pieces



- › Tools in metric sizes
- › GEDORE Check-Tool-System: 2-colour foam insert to check that the set is complete
- › Each tool is securely held in its own pocket, grip recesses facilitate removal of the tools
- › Resistant to oil and grease

€1175,⁶³
+ VAT

1/4" 1/2"

Code	No.	Contents	Pieces	Weight kg
2956527	TS-190	1/4"+1/2" socket wrench assortment in CT module no. TS CT2-D19-D20, 81 pcs Combination wrench set in CT module no. TS CT2-7, 24 pcs Tool assortment in CT module no. TS CT2-2154SK-119, 14 pcs Pliers assortment in CT module no. TS CT2-142, 28 pcs Tool assortment in 2/4 CT module no. TS CT2-6-8000, 15 pcs 1/2" set of screwdriver bits in 2/4 CT module No. TS CT2-ITX19, 28 pcs	190	17.08

TS-308

TOOL ASSORTMENT

in Check-Tool-Modules, 308 pieces

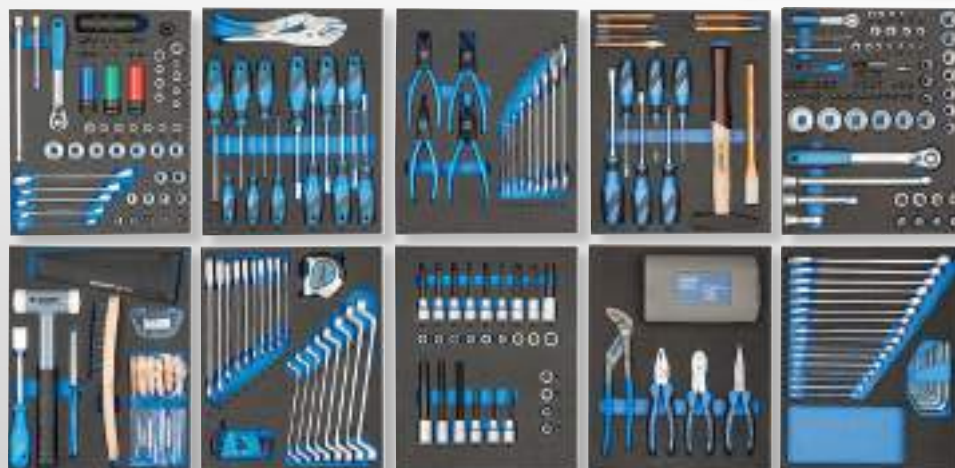

- › Tools in metric sizes
- › GEDORE Check-Tool-System: 2-colour foam insert to check that the set is complete
- › Each tool is securely held in its own pocket, grip recesses facilitate removal of the tools
- › Resistant to oil and grease
- › CT2 module = 1/2 drawer 2005 (316.5 x 390 x 35 mm)
- › CT2 suitable for 1506 XL, 1504 and 2004

€2335,²⁹
+ VAT

1/4" 3/8" 1/2"

Code	No.	Contents	Pieces	Weight kg
2956535	TS-308	1/4"+1/2" socket wrench assortment in CT module no. TS CT2-D19-D20, 81 pcs Combination wrench set in CT module no. TS CT2-7, 24 pcs Tool assortment in CT module no. TS CT2-2154SK-119, 14 pcs Pliers assortment in CT module no. TS CT2-142, 28 pcs Tool assortment in 2/4 CT module no. TS CT2-6-8000, 15 pcs 1/2" set of screwdriver bits in 2/4 CT module No. TS CT2-ITX19, 28 pcs Tool assortment in 2/4 CT module no. TS CT2-2133-2163TX, 13 pcs Wrench set in 2/4 CT module no. TS CT2-7R-2, 28 pcs Tool assortment in 2/4 CT module no. TS CT2-D30, 59 pcs Tool assortment in 2/4 CT module no. TS CT2-710, 17 pcs Hacksaw no. 407	308	30.14

1500 CT1-1993 U-20 ACCESSORIES FOR SOCKET WRENCHES 1/2"

in 1/3 Check Tool Module, 5 pieces



€125,²¹
+ VAT

12,5 1/2

- › Perfect set for hand-operated loosening and tightening of screws and nuts
- › With Check-Tool insert for quick check of tools
- › Suitable for work in sensitive areas where it must be ensured that no tools are left behind
- › Bottom layer blue, top layer black, blue indicates missing tool
- › Recessed grips facilitate the removal of the tool

Code	No.	Contents	Width mm	Depth mm	Pieces	Weight kg
2309114	1500 CT1-1993 U-20	1/2" reversible ratchet No. 1993 U-20, 1/2" T-handle No.1987, 292 mm 1/2" universal joint No. 1995, 1/2" extension No. 1990, 5 10 mm	158	310	5	1.7

1500 CT1-20 SOCKET SET 1/4"

in 1/3 Check-Tool-Module, 37 pieces



€225,²¹
+ VAT

6,3 1/4

- › Extensive range of accessories for the most common bolting applications
- › With Check-Tool insert for quick check of tools
- › Suitable for work in sensitive areas where it must be ensured that no tools are left behind
- › Bottom layer blue, top layer black, blue indicates missing tool
- › Recessed grips facilitate the removal of the tool

Code	No.	Contents	Width mm	Depth mm	Pieces	Weight kg
2308967	1500 CT1-20	1/4" socket No.20 hexagon SW 4 5 5.5 6 7 8 9 10 11 12 13 14 mm 1/4" screwdriver socket No. IN 20 hexagon SW 3 4 5 6 8 mm 1/4" screwdriver bit No. ITX 20, SW T8 T9 T10 T15 T20 T25 T27 T30 T40 mm 1/4" socket No. TX 20, E4 E5 E6 E7 E8 E10, 1/4" T-handle with slider No. 2087, 115 mm 1/4" extension No. 2090-4. 97 mm, 1/4" universal joint No. 2095 1/4" square plug-in handle No. 2098, 2K handle 1/4" reversible ratchet 2093 U-10, 127 mm	158	310	37	0.845

1500 CT1-30 SOCKET SET 3/8"

in 1/3 Check-Tool module, 24 pieces



€226,⁰⁵
+ VAT

10 3/8

- › Perfect set composition for the most common bolting cases
- › With Check-Tool insert for quick check of tools
- › Suitable for work in sensitive areas where it must be ensured that no tools are left behind
- › Bottom layer blue, top layer black, blue indicates missing tool
- › Recessed grips facilitate the removal of the tool

Code	No.	Contents	Width mm	Depth mm	Pieces	Weight kg
2308975	1500 CT1-30	3/8" hexagon socket, No. 30, SW 6 7 8 9 10 11 12 13 14 15 16 17 18 19 3/8" screwdriver socket, hexagon, No. IN 30, SW 4 5 6 8 10 mm 3/8" universal joint, No. 3095, 51 mm, 3/8" T-handle, No. 3087 3/8" extension, No. 3090 -5 -10, 125 250 mm 3/8" reversible ratchet, No. 3093 U-10, 200 mm	158	310	24	1.67

1500 CT1-350 CHISEL SET

in 1/3 Check-Tool module, 8 pieces



€76,⁸⁰
+ VAT

- › Perfect set composition for the most common stroke applications
- › With Check-Tool insert for quick check of tools
- › Suitable for work in sensitive areas where it must be ensured that no tools are left behind
- › Bottom layer blue, top layer black, blue indicates missing tool
- › Recessed grips facilitate the removal of the tool



Code	No.	Contents	Width mm	Depth mm	Pieces	Weight kg
2309041	1500 CT1-350	Flat chisel No. 97-250, 250x24 mm, Cross-cut chisel No. 98-125, 125 mm Drift punch No. 99 12-5 12-8, Ø 5 8 mm, Centre punch No. 100-12, 120x12x5 mm Pin punch, No. 119-1.5 3 4 mm Engineers' hammer ROTBAND-PLUS No.600 H-300, with hickory shaft 300g	158	310	8	1.425

1500 CT1-142 PLIERS SET

in 1/3 Check-Tool-Module, 4 pieces



€117,⁵⁶
+ VAT

- › Practical set composition for a wide range of applications in all trades
- › With Check-Tool insert for quick check of tools
- › Suitable for work in sensitive areas where it must be ensured that no tools are left behind
- › Bottom layer blue, top layer black, blue indicates missing tool
- › Recessed grips facilitate the removal of the tool



Code	No.	Contents	Width mm	Depth mm	Pieces	Weight kg
2309025	1500 CT1-142	10" water pump pliers No. 142 10 JC, 2K handle Power combination pliers no. 8250-180 JC, 180mm 2K handle Needle nose pliers no. 8132-160 JC, 160mm 2K handle Power side cutters no. 8316-160 JC, 160mm 2K handle	158	310	4	1.217

1500 CT1-8000 SET OF CIRCLIP PLIERS

in 1/3 Check-Tool module, 6 pieces



€98,³²
+ VAT

- › Perfect set composition for inner and outer retaining rings
- › With Check-Tool insert for quick check of tools
- › Suitable for work in sensitive areas where it must be ensured that no tools are left behind
- › Bottom layer blue, top layer black, blue indicates missing tool
- › Recessed grips facilitate the removal of the tool



Code	No.	Contents	Width mm	Depth mm	Pieces	Weight kg
2309181	1500 CT1-8000	Assembly pliers for external circlips no. 8000A 1A 2A 21 Assembly pliers for internal circlips no. 8000J 1J 2J 21	158	310	6	1.009

1500 CT1-2133 SOCKET SET

in 1/3 Check-Tool module, 6 pieces



€72,²⁶
+ VAT

- > Perfect set for easy and quick loosening of screws with hexagonal head and nuts
- > With Check-Tool insert for quick check of tools
- > Suitable for work in sensitive areas where it must be ensured that no tools are left behind
- > Bottom layer blue, top layer black, blue indicates missing tool
- > Recessed grips facilitate the removal of the tool



Code	No.	Contents	Width mm	Depth mm	Pieces	Weight kg
2309122	1500 CT1-2133	Socket wrench with 3C handle No. 2133, 5.5 6 7 8 9 10 mm	158	310	6	0.82

1500 CT1-2150 PH SCREWDRIVER SET

in 1/3 Check-Tool module, 6 pieces



€54,¹⁹
+ VAT

- > Perfect set for slotted and Phillips screws PH
- > With Check-Tool insert for quick check of tools
- > Suitable for work in sensitive areas where it must be ensured that no tools are left behind
- > Bottom layer blue, top layer black, blue indicates missing tool
- > Recessed grips facilitate the removal of the tool



Code	No.	Contents	Width mm	Depth mm	Pieces	Weight kg
2309130	1500 CT1-2150 PH	3K screwdriver slot no. 2150, 4 5.5 6.5 8mm 3K screwdriver Phillips No. 2160 PH 1 2	158	310	6	0.63

1500 CT1-2150 PZ SCREWDRIVER SET

in 1/3 Check-Tool module, 6 pieces



€54,¹⁹
+ VAT

- > Perfect set for slotted and Phillips screws PZ
- > With Check-Tool insert for quick check of tools
- > Suitable for work in sensitive areas where it must be ensured that no tools are left behind
- > Bottom layer blue, top layer black, blue indicates missing tool
- > Recessed grips facilitate the removal of the tool



Code	No.	Contents	Width mm	Depth mm	Pieces	Weight kg
2309149	1500 CT1-2150 PZ	3K screwdriver slot no. 2150, 4 5.5 6.5 8mm 3K screwdriver Phillips No. 2160 PZ 1 2	158	310	6	0.63

1500 CT1-2163 TX SCREWDRIVER SET

in 1/3 Check-Tool module, 6 pieces

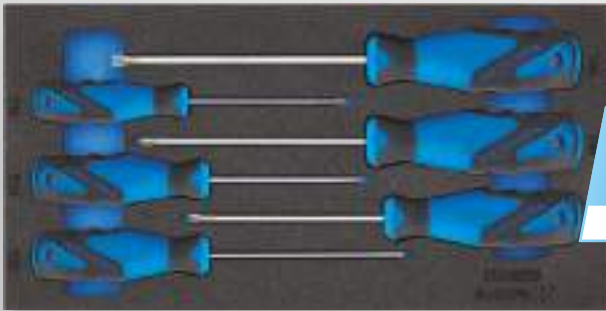

€54,19
+ VAT

- › Perfect set composition for inside TX screws
- › With Check-Tool insert for quick check of tools
- › Particularly suitable for work in sensitive areas where it must be ensured that no tools are left behind
- › Bottom layer blue, top layer black, blue indicates missing tool
- › Recessed grips facilitate the removal of the tool



Code	No.	Contents	Width mm	Depth mm	Pieces	Weight kg
2309157	1500 CT1-2163 TX	3C screwdriver recessed TX with drill hole No. 2163 TXB, AF T8 T10 T15 T20 T25 T30 mm	158	310	6	0.4

1500 CT1-2163 TXB SCREWDRIVER SET

in 1/3 Check-Tool module, 6 pieces

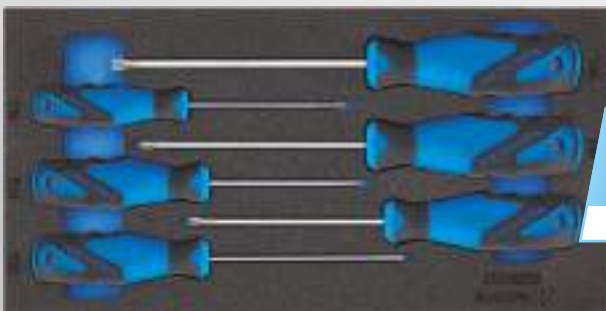

€63,27
+ VAT

- › Perfect set composition for inside TX screws with pin
- › With Check-Tool insert for quick check of tools
- › Suitable for work in sensitive areas where it must be ensured that no tools are left behind
- › Bottom layer blue, top layer black, blue indicates missing tool
- › Recessed grips facilitate the removal of the tool



Code	No.	Contents	Width mm	Depth mm	Pieces	Weight kg
2309165	1500 CT1-2163 TXB	3C screwdriver recessed TX with drill hole No. 2163 TXB, AF T10 T15 T20 T25 T30 T40 mm	158	310	6	0.5

1500 CT1-400 DOUBLE ENDED RING SPANNER SET, OPEN

in 1/3 Check Tool Module, 5 pieces



€90,67
+ VAT

- › Perfect set for the assembly of pipe fittings
- › With Check-Tool insert for quick check of tools
- › Suitable for work in sensitive areas where it must be ensured that no tools are left behind
- › Bottom layer blue, top layer black, blue indicates missing tool
- › Recessed grips facilitate the removal of the tool



Code	No.	Contents	Width mm	Depth mm	Pieces	Weight kg
2309068	1500 CT1-400	Double ended ring spanner open hex No. 400, AF 8x10 10x11 12x14 13x15 17x19 mm	158	310	5	0.565

1500 CT1-2 DOUBLE ENDED RING SPANNER SET

in 1/3 Check-Tool module, 8 pieces



€98,³²
+ VAT

- › Practical set composition for extremely deep-set or recessed nuts
- › With Check-Tool insert for quick check of tool completeness
- › Suitable for work in sensitive areas where it must be ensured that no tools are left behind
- › Bottom layer blue, top layer black, blue indicates missing tool



Code	No.	Contents	Width mm	Depth mm	Pieces	Weight kg
2308827	1500 CT1-2	Double-ended ring spanner UD profile No. 2 6x7 8x9 10x11 12x13 14x15 16x17 18x19 20x22 mm	158	310	8	1.36

1500 CT1-6 DOUBLE OPEN ENDED SPANNER SET

in 1/3 Check-Tool-Module, 10 pieces

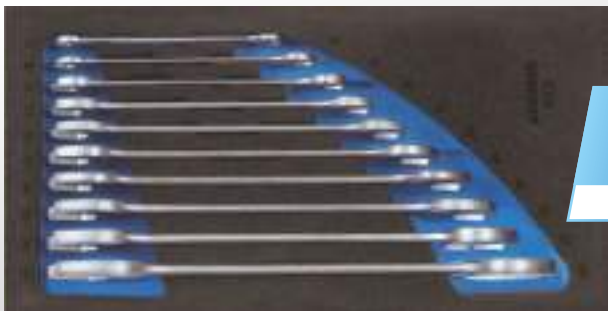

€81,³⁴
+ VAT

- › Perfect set for use on nuts and bolts
- › With Check-Tool insert for quick check of tools
- › Suitable for work in sensitive areas where it must be ensured that no tools are left behind
- › Bottom layer blue, top layer black, blue indicates missing tool



Code	No.	Contents	Width mm	Depth mm	Pieces	Weight kg
2308851	1500 CT1-6	Double open-ended spanner No. 6, AF 6x7 8x9 10x11 12x13 14x15 16x17 18x19 20x22 21x23 24x27 mm	158	310	10	1.44

1500 CT1-7 R COMBINATION RATCHET SPANNER SET

in 1/3 Check-Tool-Module, 10 pieces

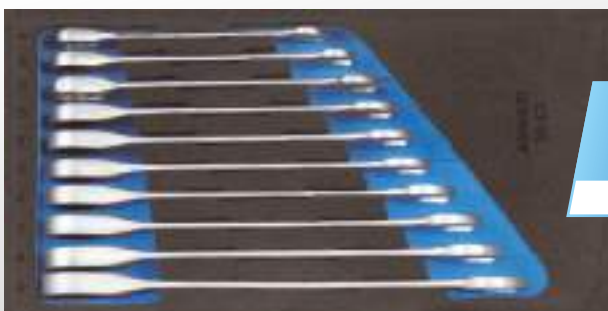

€162,¹⁸
+ VAT

- › Perfect set composition for ratcheting release and the quick suit
- › With Check-Tool insert for quick check of tools
- › Suitable for work in sensitive areas where it must be ensured that no tools are left behind
- › Bottom layer blue, top layer black, blue indicates missing tool



Code	No.	Contents	Width mm	Depth mm	Pieces	Weight kg
2308894	1500 CT1-7 R	Combination ratchet spanner No. 7 R, 8 10 12 13 14 15 16 17 18 19 mm	158	310	10	1.24

1500 CT1-7 UR COMBINATION RATCHET SPANNER SET, REVERSIBLE

in 1/3 Check-Tool-Module, 10 pieces



€226,⁰⁵
+ VAT

- › Perfect set composition for ratcheting release and the quick suit
- › Clockwise and counterclockwise rotation possible via switch lever
- › With Check-Tool insert for quick check of tool completeness
- › Particularly suitable for work in sensitive areas where it must be ensured that no tools are left behind
- › Bottom layer blue, top layer black, blue indicates missing tool
- › Recessed grips facilitate the removal of the tool



Code	No.	Contents	Width mm	Depth mm	Pieces	Weight kg
2331969	1500 CT1-7 UR	Combination ratchet spanner No. 7 UR, 8 10 12 13 14 15 16 17 18 19 mm	158	310	10	1.245

1500 CT1-D 19 SOCKET SET 1/2", UD-PROFILE

in 1/3 check tool module, 26 pieces



€198,³²
+ VAT

- › Perfect set composition for hand-operated bolting applications
- › With Check-Tool insert for quick check of tools
- › Suitable for work in sensitive areas where it must be ensured that no tools are left behind
- › Bottom layer blue, top layer black, blue indicates missing tool



Code	No.	Contents	Width mm	Depth mm	Pieces	Weight kg
2308916	1500 CT1-D 19	Socket 1/2" No. D 19, SW 10 11 12 13 14 15 16 17 18 19 21 22 23 24 26 27 28 30 32 mm Screwdriver socket 1/2" No. IN 19, SW 6 7 8 9 10 12 14 mm	158	310	26	2.68

1500 CT1-IN 19 LKM SCREWDRIVER BIT SOCKET SET 1/2"

in 1/3 Check-Tool module, 13 pieces



€144,⁵⁴
+ VAT

- › Perfect set for hexagon socket screws
- › With Check-Tool insert for quick check of tools
- › Suitable for work in sensitive areas where it must be ensured that no tools are left behind
- › Bottom layer blue, top layer black, blue indicates missing tool



Code	No.	Contents	Width mm	Depth mm	Pieces	Weight kg
2308932	1500 CT1-IN 19 LKM	Screwdriver socket 1/2" No. IN 19, SW 6 7 8 10 12 14 mm Screwdriver socket 1/2" No. IN 19 L 6-140 7-140 8-140 9-140 10-140 12-140 14-140	158	310	13	1.9

1500 CT1-INX 19 LK SCREWDRIVER BIT SOCKET SET 1/2"

in 1/3 Check-Tool module, 11 pieces



€170,⁵⁹
+ VAT



Code	No.	Contents	Width mm	Depth mm	Pieces	Weight kg
2957957	1500 CT1-INX 19 LK	INX 19 8 10 12 14 16 18, INX 19 L 6-100 8-100 10-100 12-100 14-100	158	310	11	1.044

1500 CT1-HTX 19 LKP SCREWDRIVER BIT SOCKET SET 1/2"

in 1/3 Check-Tool module, 19 pieces



€233,⁶¹
+ VAT



Code	No.	Contents	Width mm	Depth mm	Pieces	Weight kg
2308940	1500 CT1-HTX 19 LKP	Screwdriver bit 1/2" No. ITX 19 T20 T25 T27 T30 T40 T45 T50 T55 T60 Screwdriver bit 1/2" No. ITX 19 L T20-100 T25-100 T27-100 T30-100 T40-100 T45-100 T50-100 T55-100 T60-100, TX screw gauge no. 708	158	310	19	1.915

1500 CT1-HTX 30 SCREWDRIVER BIT SOCKET SET 3/8"

in 1/3 Check-Tool-Module, 39 pieces



€342,⁰²
+ VAT



Code	No.	Contents	Width mm	Depth mm	Pieces	Weight kg
2308983	1500 CT1-HTX 30	Socket 3/8" No. TX 30 E5 E6 E7 E8 E10 E11 E12 E14 Screwdriver socket 3/8" No. IN 30 L, hexagon SW 4 5 6 7 8 10 mm Screwdriver bit 3/8" No. ITX 30 T20 T25 T27 T30 T40 T45 T50 Screwdriver bit 3/8" No. ITX 30 L T20 T25 T27 T30 T40 T45 T50 Screwdriver socket 3/8" slot No. IS 30, SW 5.5 6.5 8 10 12 mm Screwdriver bit 3/8" No. IKS 30 1 2 3, Screwdriver socket 3/8" No. IKS 30 PZD 1 2 3	158	310	39	2.175

- > Perfect set for inside 12-sided screws
- > With Check-Tool insert for quick check of tools
- > Suitable for work in sensitive areas where it must be ensured that no tools are left behind
- > Bottom layer blue, top layer black, blue indicates missing tool

- > Perfect set composition for inside TX screws
- > With Check-Tool insert for quick check of tools
- > Suitable for work in sensitive areas where it must be ensured that no tools are left behind
- > Bottom layer blue, top layer black, blue indicates missing tool
- > Recessed grips facilitate the removal of the tool

- > Perfect set composition for internal TX screws
- > With Check-Tool insert for quick check of tools
- > Suitable for work in sensitive areas where it must be ensured that no tools are left behind
- > Bottom layer blue, top layer black, blue indicates missing tool
- > Recessed grips facilitate the removal of the tool

1500 CT1-K 1900 IMPACT DRIVER SET 1/2"

in 1/3 Check-Tool-Module, 23 pieces

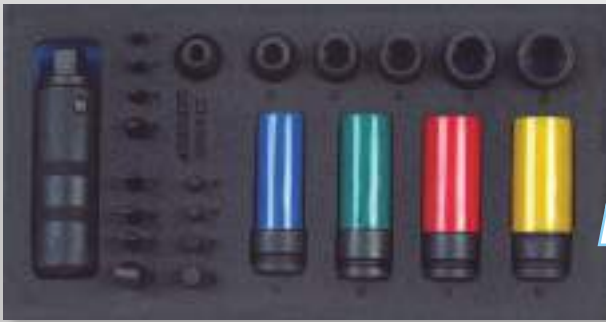

€192,44
+ VAT

- > With powerful screw loosener for removing stuck screws
- > With Check-Tool insert for quick check of tool completeness
- > Particularly suitable for work in sensitive areas where it must be ensured that no tools are left behind
- > Bottom layer blue, top layer black, blue indicates missing tool
- > Recessed grips facilitate the removal of the tool

12,5 1/2"

Code	No.	Contents	Width mm	Depth mm	Pieces	Weight kg
2309092	1500 CT1-K 1900	K 19 10 13 14 17 19, K 19 LS 17 19 21 22, 880 7 8 9 12 885 5 6 8 10, 890 1 2 3 4, KB 819, K 1900	158	310	23	2.645

1500 CT1-VDE 142 VDE PLIERS SET

in 1/3 Check-Tool module, 4 pieces

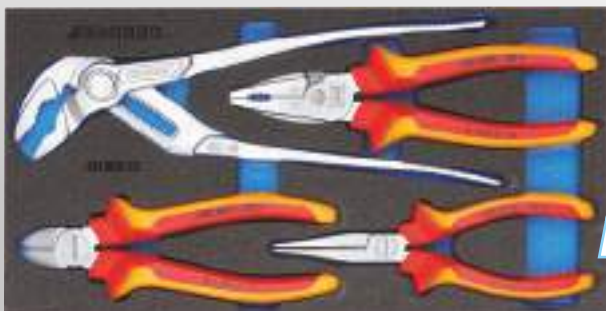

€112,61
+ VAT

- > Practical set composition for a wide range of applications in the electronics sector
- > With Check-Tool insert for quick check of tools
- > Suitable for work in sensitive areas where it must be ensured that no tools are left behind
- > Bottom layer blue, top layer black, blue indicates missing tool
- > Recessed grips facilitate the removal of the tool

1000 V

Code	No.	Contents	Width mm	Depth mm	Pieces	Weight kg
2309033	1500 CT1-VDE 142	Water pump pliers no. 142 10c, 10" VDE power combination pliers no. VDE 8250-180H VDE needle nose pliers no. VDE 8132-160 H, VDE side cutter no. VDE 8314-160 H	158	310	4	1.158

1500 CT1-VDE 2170 PZ VDE SCREWDRIVER SET

in 1/3 Check-Tool module, 6 pieces

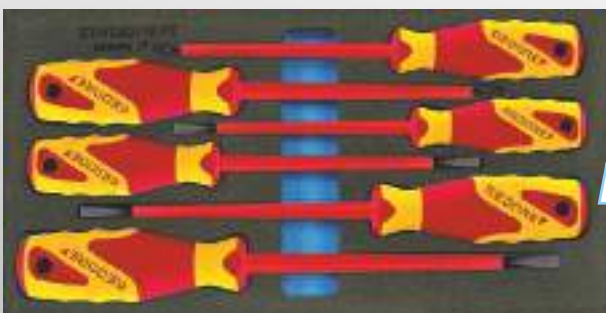

€63,27
+ VAT

- > Perfect set for slotted and Phillips PZ screws in the electronics sector
- > With Check-Tool insert for quick check of tools
- > Suitable for work in sensitive areas where it must be ensured that no tools are left behind
- > Bottom layer blue, top layer black, blue indicates missing tool
- > Recessed grips facilitate the removal of the tool

1000 V

Code	No.	Contents	Width mm	Depth mm	Pieces	Weight kg
2309173	1500 CT1-VDE 2170 PZ	VDE slotted screwdriver no. VDE 2170, SW 4.5 5 6.5 8 mm VDE screwdriver Phillips No. VDE 2160 PZ 1 2	158	310	6	0.625

1500 CT2-7 COMBINATION SPANNER SET

in 2/3 Check-Tool-Module,
25 pieces

€180,⁶⁷
+ VAT

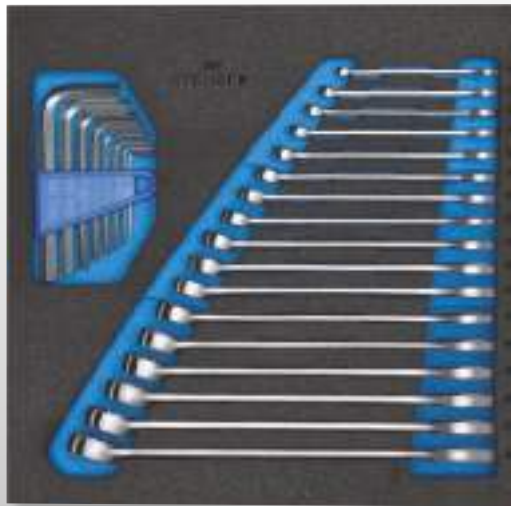

- › Perfect set composition for universal use
- › With Check-Tool insert for quick check of tools
- › Suitable for work in sensitive areas where it must be ensured that no tools are left behind
- › Bottom layer blue, top layer black, blue indicates missing tool
- › Recessed grips facilitate the removal of the tool



Code	No.	Contents	Width mm	Depth mm	Pieces	Weight kg
2308878	1500 CT2-7	Combination wrench No. 7, 6 7 8 9 10 11 12 13 14 15 16 17 18 19 20 21 22 mm Offset screwdriver set No. PH 42-88 hexagon 2 2.5 3 4 5 6 8 10 mm	315	310	25	1.75

1500 CT2-7-32 COMBINATION SPANNER SET

in 2/3 Check-Tool module,
5 pieces

€112,⁶¹
+ VAT



- › Perfect set composition for universal use
- › With Check-Tool insert for quick check of tools
- › Suitable for work in sensitive areas where it must be ensured that no tools are left behind
- › Bottom layer blue, top layer black, blue indicates missing tool
- › Recessed grips facilitate the removal of the tool



Code	No.	Contents	Width mm	Depth mm	Pieces	Weight kg
2308886	1500 CT2-7-32	Combination spanner No. 7, 23 24 27 30 32 mm	315	310	5	1.865

1500 CT2-DT 2142 HEXAGON SOCKET KEY SET

in 2/3 Check-Tool module,
9 pieces

€108,⁴⁰
+ VAT

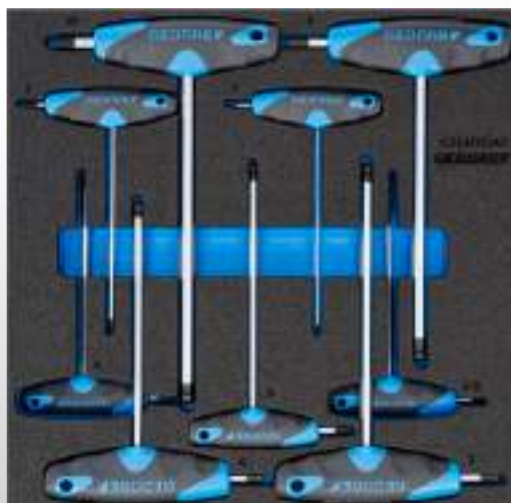

- › Perfect set for hexagon socket screws
- › With Check-Tool insert for quick check of tools
- › Suitable for work in sensitive areas where it must be ensured that no tools are left behind
- › Bottom layer blue, top layer black, blue indicates missing tool
- › Recessed grips facilitate the removal of the tool



Code	No.	Contents	Width mm	Depth mm	Pieces	Weight kg
2309009	1500 CT2-DT 2142	Offset screwdriver with 2CT-handle No. DT 2142, 2 2.5 3 4 5 6 7 8 10 mm	315	310	9	0.9

1500 ED-70 K DISTANCE MODULE

empty



€9,07
+ VAT

- For balancing and fixing tool modules No. 1500 ES in drawers of depth 400 mm, for tool trolleys No. 2004 and workbenches No. 1502, 1504, 1505 and 1506 XL
- Made of impact-resistant ABS plastic, black grained



Code	No.	Width mm	Depth mm	Height mm	Weight kg
1618687	1500 ED-70 K	475	77	40	0.12

1500 ED-70 S DISTANCE MODULE 1/3

empty



€18,06
+ VAT

- For tool trolley No. WSL-L7 (workster) and No. 2005, workbench No. 1504 XL and tool chest No. 2430, suitable as spacer for 1/3 module
- Module in sheet steel

Code	No.	Width mm	Depth mm	Height mm	Weight kg
1851462	1500 ED-70 S	152	77	40	0.15

1500 ED-70 XL DISTANCE MODULE

empty



€21,67
+ VAT

- Suitable to take torque wrenches and other long hand tools or small pieces
- For tool trolley No. WSL-L7 (workster) and No. 2005, workbench No. 1504 XL and tool chest No. 2430
- Module in sheet steel

Code	No.	Width mm	Depth mm	Height mm	Weight kg
1803069	1500 ED-70 XL	625	77	40	0.854

1500 CTD-20 BIT SOCKET ASSORTMENT 1/4"

in Check-Tool-Module, 45 pieces

€179,83
+ VAT



- Multi-grip 1/4" with extensive range of bits and sockets
- Only suitable for tool trolley 2004, and workbenches 1502, 1504, 1505 and 1506 XL
- For models No. 2005, No. WSL-L7 (workster), No. 2430 and No. 1504 XL order additional distance module No. 1500 ED-70 S



Code	No.	Contents	Width mm	Height mm	Depth mm	Pieces	Weight kg
1733419	1500 CTD-20 BIT	1/4" socket wrench insert No. 20 L, 4 4.5 5 6 7 8 9 10 12 13 mm 1/4" screwdriver bit No. 680, 4 5.5 6.5 8 mm 1/4" screwdriver bit No. 685, 2.5 3 4 5 6 mm 1/4" screwdriver bit No. 685 X 5 6 8 mm 1/4" screwdriver bit No. 687 TX T6 T7 T8 T9 T10 T15 T20 T25 T27 T30 T40 1/4" screwdriver bit No. 690 1 2 3 1/4" screwdriver bit No. 690 PZD 1 2 3 Miniature LED light No.649, Insert holder No. 673 6,3 Bit holder No. 699, 1/4" bit adapter No. 620 Multi-handle No. 676, Combination holding tool No. 639	475	40	77	45	0.7

2005 CT2-D 19L SOCKET ASSORTMENT 1/2"

in 2/4 Check-Tool-Module, 40 pieces

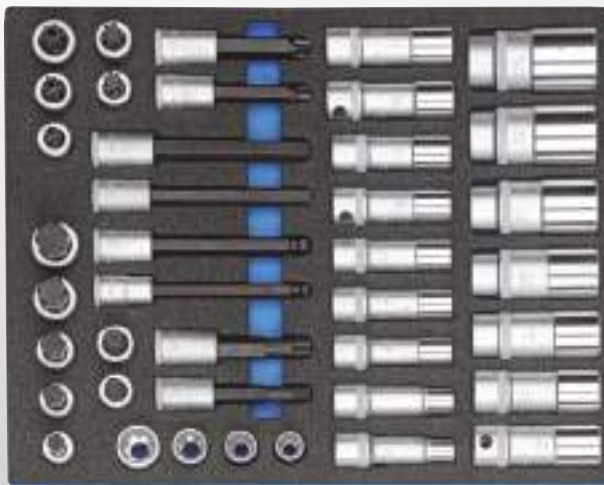

- > Optimum range for deeper screws in the most common wrench sizes
- > With Check-Tool insert for quick check of tool completeness
- > Particularly suitable for work in sensitive areas where it must be ensured that no tools are left behind.
- > Bottom layer blue, top layer black, blue indicates missing tool
- > Recessed grips make it easier to remove the tool

€550,⁴²_{+ VAT}



Code	No.	Contents	Width mm	Depth mm	Pieces	Weight kg
2016516	2005 CT2-D 19L	D 19 L 10 12 13 14 15 16 17 18 19 21 22 24 27 30 32 34 IN 19 10 12 14 17 19 IN 19 L 12-140 14-140 IN 19 LK 10-140 12-140 INX 19 12 14 INX 19 L 12-100 14-100 ITX 19 T55 T60 ITX 19 L T55-100 T60-100 ITX 19 B T50 T55 T60 TX 19 E16 E18 E20 E24	316	390	40	6.9

2005 CT3-32 SOCKET ASSORTMENT 3/4"

in 3/4 check tool module, 14 pieces



- > Perfect set for hand-operated sockets and connecting parts with square drive
- > With Check-Tool insert for quick check of tool completeness
- > Suitable for work in sensitive areas where it must be ensured that no tools are left behind
- > Bottom layer blue, top layer black, blue indicates missing tool
- > Recessed grips facilitate the removal of the tool

€377,³¹_{+ VAT}



Code	No.	Contents	Width mm	Depth mm	Pieces	Weight kg
2752727	2005 CT3-32	Socket 3/4" hexagon UD profile No. 32, SW 22 24 27 30 32 36 38 41 46 50 Extension 3/4" No. 3290-8 -16 200 mm, 400 mm Reversible ratchet 3/4" No. 3293 U-2, 510 mm T-handle 3/4" No. 3287	472	390	14	9

2005 CT4-7 XL COMBINATION SPANNER SET

in 4/4 check tool module, 18 pieces

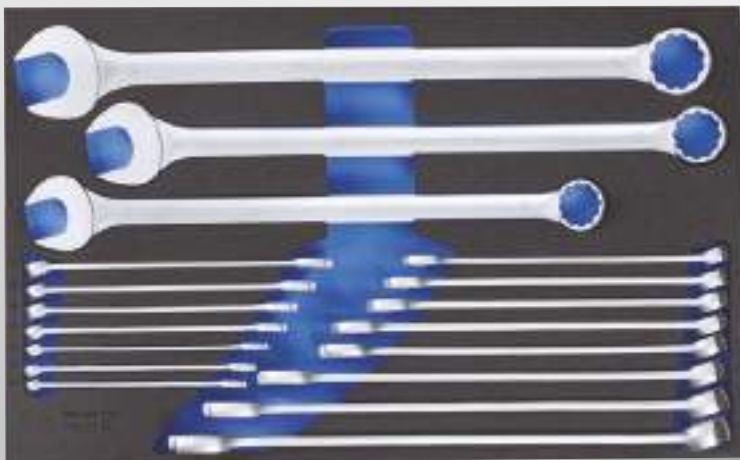

- › Perfect set composition for gentle screw operation
- › Combination spanner extra long for more torque
- › With Check-Tool insert for quick check of tool completeness
- › Suitable for work in sensitive areas where it must be ensured that no tools are left behind
- › Bottom layer blue, top layer black, blue indicates missing tool
- › Recessed grips facilitate the removal of the tool

€451,²⁶
+ VAT



Code	No.	Contents	Width mm	Depth mm	Pieces	Weight kg
2704226	2005 CT4-7 XL	Combination spanner No. 7 XL, 10 11 12 13 14 15 16 17 18 19 21 22 24 27 30 32 36 41 mm	633	390	18	8.15

2005 CT4-1B COMBINATION SPANNER SET

in 4/4 check tool module, 25 pieces

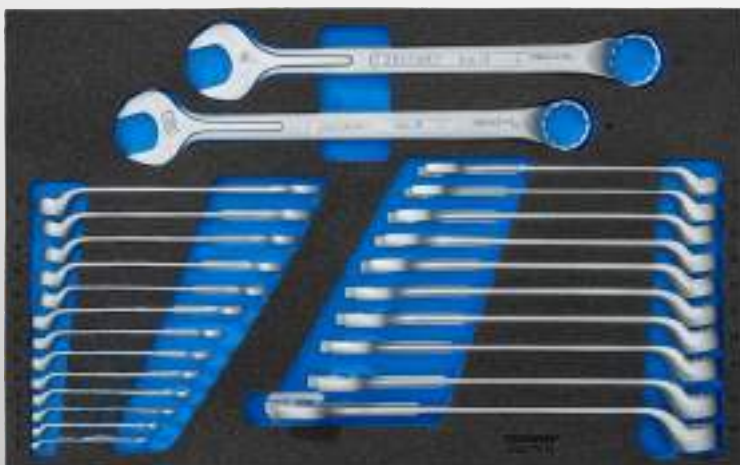

- › Shaft reinforced by power ribs on the jaw side guarantees maximum torque
- › With UD profile for easy power transmission
- › Ring cranked and 10° angled
- › ideal for countersunk or low-lying nuts and bolts
- › With check tool insert for quick identification of missing tools
- › Perfect for work areas where it must be ensured that no tools are left behind
- › Underlay blue, upper layer black, blue indicates missing tool
- › Recessed grips make it easier to remove the tool

€432,⁷⁷
+ VAT

Code	No.	Contents	Width mm	Depth mm	Pieces	Weight kg
3434982	2005 CT4-1B	Combination wrench no. 1 B, SW 6 7 8 9 10 11 12 13 14 15 16 17 18 19 20 21 22 23 24 25 26 27 28 29 30 32 34mm	633	390	25	6.2

2005 CT4-8000 TOOL ASSORTMENT

in 4/4 check tool module, 13 pieces



€293,²⁸
+ VAT



- > With Check-Tool insert for quick check of tools
- > Suitable for work in sensitive areas where it must be ensured that no tools are left behind.
- > Bottom layer blue, top layer black, blue indicates missing tool
- > Recessed grips facilitate the removal of the tool

Code	No.	Contents	Width mm	Depth mm	Pieces	Weight kg
2016303	2005 CT4-8000	Machinist's hammer ROTBAND-PLUS No. 600H-300-500 Recoil-free soft-face hammer no. 248 ST-40 Universal pliers no. 142 10JC, Needle nose pliers no. 8132-160JC Power side cutters no. 8316-160JC, Power combination pliers no. 8250-180JC Assembly pliers for external circlips no. 8000A 1 2 21 Assembly pliers for internal circlips no. 8000 J 1 2 21	633	390	13	4.1

2005 CT4-U-20 SOCKET SET 1/4"-3/8"-1/2"

in 4/4 check tool module, 91 pieces



€948,⁷⁴
+ VAT



- > Extensive 1/4"-3/8"-1/2" set for universal use
- > With Check-Tool insert for quick check of tool completeness
- > Particularly suitable for work in sensitive areas where it must be ensured that no tools are left behind
- > Bottom layer blue, top layer black, blue indicates missing tool
- > Recessed grips facilitate the removal of the tool

Code	No.	Contents	Width mm	Depth mm	Pieces	Weight kg
2016257	2005 CT4-U-20	1/4" socket No. 20, SW 5.5 6 7 8 9 10 11 12 13 14 mm 1/4" reversible ratchet No. 2093 U-201/4" T-handle ratchet No. 2093U-3T 1/4" extension No. 2090-4-6, 97 148 mm, 1/4" universal joint No. 2095 3/8" socket No. D 30, SW 8 9 10 11 12 13 14 15 16 17 18 19 21 22 mm 3/8" screwdriver socket No. IN 30 L, SW 4 5 6 7 8 10 3/8" screwdriver bit No. ITX 30 L, T20 T25 T27 T30 T40 T45 T50 3/8" socket No. TX 30, E5 E6 E7 E8 E10 E11 E12 E14 3/8" screwdriver socket No. IKS 30, 1 2 3, 3/8" screwdriver socket No. IKS 30 PZD 1 2 3 3/8" screwdriver socket No. IS 30, SW 5.5 6.5 8 10 12 mm 3/8" spark plug insert with retaining spring 20.8 mm 3/8" spark plug insert with retaining spring 16 mm 3/8" spark plug insert with retaining spring 18 mm, 3/8" reversible ratchet No. 3093 U-20 3/8" extension with trigger No. 3090 A-5-10, 3/8" universal joint No. 3095 1/2" socket No. D 19, SW 10 11 12 13 14 15 16 17 18 19 21 22 23 24 27 30 32 mm 1/2" reversible ratchet 1/2" no. 1993 U-20, 1/2" extension 1/2" no. 1990-5-10, 125 250mm 1/2" reducer 1/2" to 3/8" No. 1930, 1/2" universal joint 1/2" no. 1995 1/2" articulated handle No. 1996, 255 mm	633	390	91	7.64

THE ORGANIZATIONAL TALENT FOR ON THE GO

The **GEDORE** tool box module **WorkMO B3 1110 WM 321** is the practical solution for craftsmen on tour or mobile service employees

The robust, resilient **module WorkMO B3 1110 WM 321** is made of a light aluminum-plastic mix and weighs only around 22 kg. Nevertheless, the two fully extendable drawers can each be loaded with up to 60 kg. In combination with the

GEDORE 1500 ES/1500 CT foam tool modules, all tools are perfectly stowed away and organized during mobile service calls. Rounded plastic edges serve as protection against impact and scratches and make the box even more robust. Under the drawers there is a compartment with a lock for **GEDORE** L-BOXX® 136 no. 1100 L and for **GEDORE** S-BOXX® no. 1110 WMSB 3. The WorkMo B3 is compatible with Sortimo® in-vehicle equipment and load securing and is also crash-tested.



Tool box module WorkMo B3 1110 WM 321

1

PERFECTLY ORGANIZED

- With two heavy-duty drawers for tool modules and a compartment for L-BOXXES, the WorkMo B3 offers plenty of space for orderly tool storage

2

COMPACT

- With the dimensions W 789 x D 396 x H 506 mm and a weight of 22 kg, the box module is ideal for use in a service vehicle

3

LIGHT AND ROBUST

- The box module from GEDORE is made from a light but highly resilient aluminium-plastic mix, up to 50% lighter than comparable solutions



„As a mobile service employee, I need a system that allows me to keep my equipment tidy. The box module from GEDORE is the perfect solution for my work.“

1110 WM 321 TOOL BOX MODULE WORKMO B3

2 drawers H6, compartment for L-BOXX® + S-BOXX®

- > 2 drawers with full extension suitable for GEDORE 1500 ES/1500 CT modules
- > Compatible with Sortimo® interior vehicle fittings and load safety
- > Load capacity per drawer 60 kg



€450,42 + VAT

Code	No.	Width mm	Height mm	Depth mm	Weight kg
2954354	1110 WM 321	789	506	396	22.12

1110 WMW-S-03 WORKMO B3 WITH RANGE OF TOOLS

110 pieces

- > Ideal for large and small maintenance and assembly work
- > Suitable for industry, trade, automotive and the ambitious do-it-yourselfer
- > Modular tool trolley
- > Mobile as a complete unit or each module individually portable
- > Ideal for transportation from the workshop to changing workplaces
- > 6 drawers with full extension suitable for GEDORE 1500 ES/1500 CT modules
- > For 4x 1/3 modules or 2x 2/3 modules
- > One compartment with lock for GEDORE L-BOXX® 136 No. 1100 L and for GEDORE S-BOXX® No. 1110 WMSB 3 (both not included in the scope of delivery)
- > Light and sturdy aluminum-plastic mix
- > Mobile with roller skids with 4 swivel castors, 2 of them with total brake
- > Wooden worktop for assembly work on site
- > Compatible with Sortimo® interior vehicle fittings and load safety



€1957,14 + VAT



Code	No.	Height mm	Width mm	Depth mm	Contents	Number of drawers	Pieces	Weight kg
3005194	1110 WMW S-03	1.140	845	550	Workshop car no. 1110 WMW-3, GEDORE L-BOXX® 136 No. 1100 L S-BOXX® B3 No. 1110 WMSB 3 Tool assortment No. 1110 CTB3-01 Tool assortment No. 1110 CTB3-02 1110 WMW-3, 1100 L, 1110 WMSB 3, 1110 CTB3-01, 1110 CTB3-02	6	110	64.3

1110 WMHP 3
WOOD PLATE FOR
WORKMO B3



- > 20 mm thick multiplex beech wood worktop
- > To fit in the plastic top to get an additional work surface

€135,²⁹
+ VAT

Code	No.	Width mm	Height mm	Depth mm	Weight kg
2954370	1110WMHP 3	835	41	426	4.5

1110 WMR 34
ROLLER FOR
WORKMO B3



- > Roller for the tool box modules mobile
- > Compatible with Sortimo® interior vehicle fittings and load safety
- > Load capacity: 200 kg

€197,⁴⁸
+ VAT

Code	No.	Width mm	Height mm	Depth mm	Weight kg
3002713	1110WMR 34	854	144	493	9

1110 WMW-3
TOOL TROLLEY
WORKMO B3

€1133,⁶¹
+ VAT



- > Consisting of: No. 1110 WM 34, 1110 WM 321, 1110 WMR 23 and 1110 WMHP 3
- > 6 drawers with full extension suitable for GEDORE 1500 ES/1500 CT modules
- > Wooden worktop for assembly work
- > Compatible with Sortimo® interior vehicle fittings and load safety

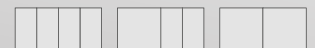

Code	No.	Width mm	Height mm	Depth mm	Weight kg
2954443	1110WMW-3	845	1.140	550	52.8

1110 WM 221

TOOL BOX MODULE WORKMO B2

2 drawers H6, compartment for L-BOXX®

- › 2 drawers with full extension suitable for GEDORE 1500 ES/1500 CT modules
- › Compatible with Sortimo® interior vehicle fittings and load safety
- › Load capacity per drawer 30 kg

€315¹³
+ VAT



Code	No.	Width mm	Height mm	Depth mm	Weight kg
2954338	1110 WM 221	526	396	506	15.26

1110 WMW-S-02

WORKMO B2 WITH TOOL ASSORTMENT

72 pieces



€1192⁴⁴
+ VAT

- › Ideal for large and small maintenance and assembly work
- › Suitable for industry, trade, automotive and the ambitious do-it-yourselfer
- › Modular tool trolley
- › Mobile as a complete unit or each module individually portable
- › Ideal for transportation from the workshop to changing workplaces
- › 6 drawers with full extension suitable for GEDORE 1500 ES/1500 CT modules
- › For 2x 1/3 modules or 1x 2/3 module
- › One compartment with locking device for GEDORE L-BOXX® 136 No. 1100 L (not included)
- › Light and sturdy aluminum-plastic mix
- › Mobile with roller skids with 4 swivel castors, 2 of them with total brake
- › Wooden worktop for assembly work
- › Compatible with Sortimo® interior vehicle fittings and load safety

Code	No.	Height mm	Width mm	Depth mm	Contents	Number of drawers	Pieces	Weight kg
3005186	1110 WMW-S-02	1.140	580	550	Workshop car no. 1110 WMW-2 GEDORE L-BOXX® 136 No. 1100 L Tool assortment No. 1110 CTB2-01 Tool assortment No. 1110 CTB2-02	6	72	50.5

1110 WMHP 2
WOOD PLATE FOR
WORKMO B2

€90,⁶⁷
+ VAT



- > 20 mm thick multiplex beech wood worktop
- > To fit in the plastic top to get an additional work surface

Code	No.	Width mm	Height mm	Depth mm	Weight kg
2954362	1110WMHP 2	572	41	426	4.5

1110 WMR 24
ROLLER FOR
WORKMO B2

€152,⁹⁴
+ VAT



- > Roller for the tool box modules mobile
- > Compatible with Sortimo® interior vehicle fittings and load safety
- > Load capacity: 200 kg

Code	No.	Width mm	Height mm	Depth mm	Weight kg
3002721	1110WMR 24	612	144	493	8

1110 WMW-2
TOOL TROLLEY
WORKMO B2

€814,²⁹
+ VAT



- > Consisting of: No. 1110 WM 24, 1110 WM 221, 1110 WMR 23 and 1110 WMHP 2
- > 6 drawers with full extension suitable for GEDORE 1500 ES/1500 CT modules
- > Wooden worktop for assembly work
- > Compatible with Sortimo® interior vehicle fittings and load safety



Code	No.	Width mm	Height mm	Depth mm	Weight kg
2954435	1110WMW-2	580	1.140	550	42.6

1.04/HP1A-B
UNIVERSAL PULLER
HIGH POWER

2-arm pattern,
 rigid legs w/leg brake

- > Spreader beam specially hardened and tempered, load with double traction force possible
- > Pulling legs forged from one piece
- > With leg brake
- > Adjustment scale for uniform adjustment of the puller hooks



€98,²⁴
 + VAT

Code	No.	Clamping width (max.) external pulling mm	Clamping width (min.) internal pulling mm	Clamping width (max.) internal pulling mm	Usable clamping reach mm	Tractive force (max.) t	Spindle thread size	Width across flats mm	Width of hooked foot mm	Usable depth of hooked foot mm	Thickness of hooked foot at tip	Graduation	Weight kg
1981145	1.04/HP1A-B	130	70	170	100	5	M14x1,5x140	17 mm	22	15	3,0	x	1.2

1.04/ST-HP-B
PULLER-SET
 with stand

- > Consisting of 3 pullers in different sizes
- > Spreader beam specially hardened and tempered, load with double traction force possible
- > Pulling legs forged from one piece
- > With leg brake
- > Adjustment scale for uniform adjustment of the puller hooks



€541,¹⁸
 + VAT

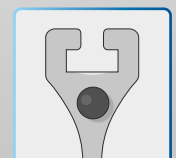
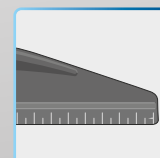
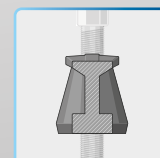

Code	No.	Contents	Weight kg
2300044	1.04/ST-HP-B	1.04/HP1A-B Puller HIGH POWER 2-armed 130x100 mm 1.04/HP2A-B Puller HIGH POWER 2-armed 200x150 mm 1.04/HP3A-B Puller HIGH POWER 2-armed 350x200 mm 1.04/97 Stand empty for 1.04 series	14.4

1100-1.04

UNIVERSAL PULLER SET

in L-BOXX® 136, 13 pieces

- › With 2- and 3-arm cross-beam
- › With rigid and slim legs and extensions
- › Extra slim Pulling hooks for narrow installation spaces are included for self-installation
- › 12 different pullers can be combined



€536,⁹⁷
+ VAT

Code	No.	Contents	Length mm	Width mm	Height mm	Pieces	Weight kg
2838362	1100-1.04	Universal puller HIGH POWER No. 1.04/HP1A-B, 2-arm, 130x100 mm Cross-beam No. 107/1A03, 3-arm 180 mm Pulling leg No. 106/A-100-B, all-steel, leg brake 3x extension No. 106/A-100-VB with leg brake 100 mm 3x pulling leg No. 106/A-100-S, slim 100 mm 3x pulling leg No. 106/S101-S, without clamping part Spindle No. 1.1406200, 17 M14x1,5 200 mm + GEDORE L-BOXX® 136 No. 1100 L	357	442	151	13	6.3

1.18/OXS PULLER

2-arm pattern,
with extra slim legs



- › Very slim forged legs
- › Particularly suitable for space conditions that are difficult to access, e.g. in the electric motor area

€40,⁶⁶
+ VAT

Code	No.	Clamping width (max.) external pulling mm	Usable clamping reach mm	Tractive force (max.) t	Spindle thread size	Width of hooked foot mm	Usable depth of hooked foot mm	Thickness of hooked foot at tip	tip diameter	Weight kg
2018594	1.18/OXS	50	70	0.5	M 10x1,5 x 100	8	3	2,0	2,9	0.24

1.19/OXS PULLER

3-arm pattern,
with extra slim legs

€58,⁷³
+ VAT



- > Very slim forged legs
- > Particularly suitable for space conditions that are difficult to access, e.g. in the electric motor area

Code	No.	Clamping width (max.) external pulling mm	Usable clamping reach mm	Tractive force (max.) t	Spindle thread size	Width of hooked foot mm	Usable depth of hooked foot mm	Thickness of hooked foot at tip	tip diameter	Weight kg
2018608	1.19/OXS	50	70	0.8	M 10x1,5 x 100	8	3	2,0	2,9	0.3

1.12/2 PULLER

2-arm pattern

€81,³⁴
+ VAT



- > Handy robust model for the removal of pulleys, wheels, ball bearings, etc.
- > Inexpensive economy model
- > The legs grip automatically

Code	No.	Clamping width (max.) external pulling mm	Usable clamping reach mm	Tractive force (max.) t	Spindle thread size	Width across flats mm	Width of hooked foot mm	Usable depth of hooked foot mm	Thickness of hooked foot at tip	Weight kg
8003410	1.12/2	130	160	5	M 18x1,5 x 200	19 mm	25	14	3,0	1.9

1.13/2 PULLER

3-arm pattern

€107,⁵⁶
+ VAT



- > Handy robust model for the removal of pulleys, wheels, ball bearings, etc.
- > Inexpensive economy model
- > The legs grip automatically

Code	No.	Clamping width (max.) external pulling mm	Usable clamping reach mm	Tractive force (max.) t	Spindle thread size	Width across flats mm	Width of hooked foot mm	Usable depth of hooked foot mm	Thickness of hooked foot at tip	Weight kg
8004300	1.13/2	130	160	7.5	M 18x1,5 x 200	19	25	14	3,0	2.5

SIMPLY SEPARATE AND PEEL OFF

A separator and puller set for tight fitting tapered roller bearings, ball bearings, inner races, battery terminals and other thin-walled parts up to a diameter of 70 mm and an installation depth of 125 mm.

The **separating puller set 1101-1.40-1.12-13** from **GEDORE** contains a separating device and puller in two different sizes including the matching spindles. To remove tightly fitting or thin-walled components, the sharp separating blades, which can be used on both sides, are

pressed behind the part to be removed and safely removed with the removal device. Depending on requirements, the pullers can be used as two-arm or three-arm pullers. The self-pressing hooks make it particularly easy to use - another plus in addition to the safety and durability of the forged parts. The complete squeegee set is housed completely sunk in a foam insert. The set not only fits perfectly in the supplied L-BOXX, but is also stackable or fits in the drawer of a tool trolley.

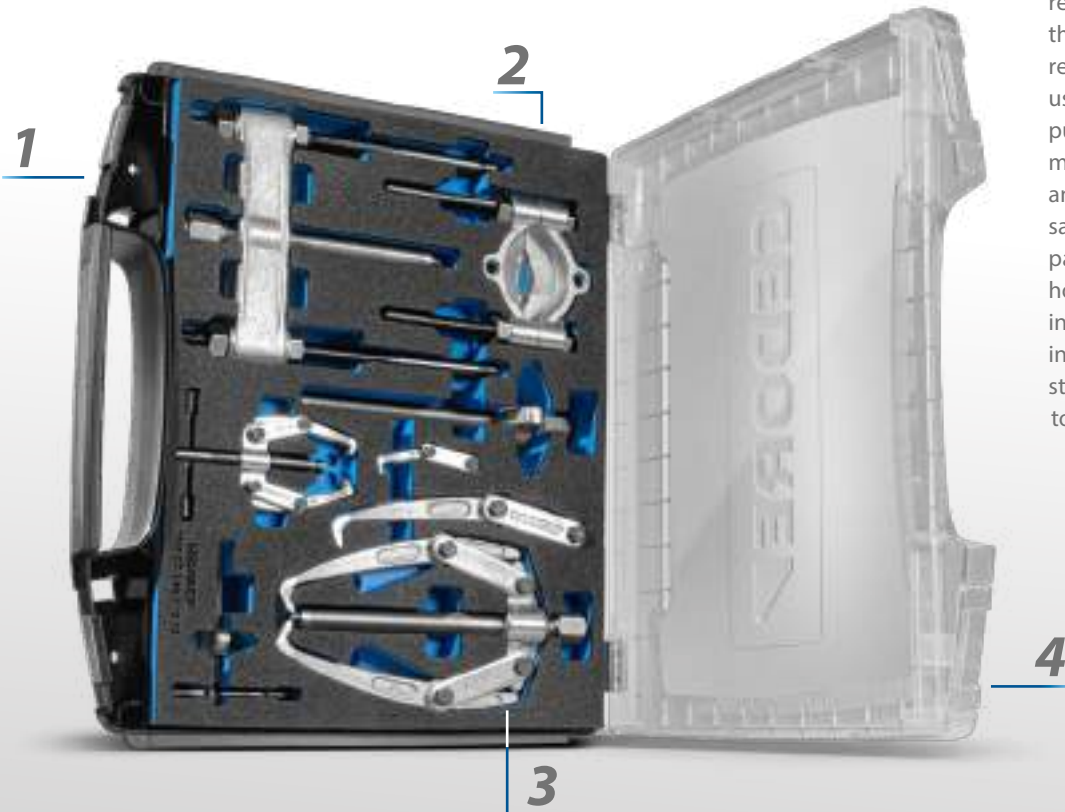

Separator and puller set with two and three arms 1101-1.40-1.12-13

1

SIMPLE APPLICATION

- Puller with self-tightening hook and separating blade usable on both sides

2

MANY USES

- For tight fitting and thin-walled components up to 70 mm in diameter and 125 mm installation depth

3

2 IN 1 PULLER

- Conversion from two-armed to three-armed pullers in a few simple steps

4

EASILY STOWED STATIONARY AND MOBILE

- In the tool trolley or in the supplied i-BOXX – the foam insert fits



„The puller set makes it easy for me: I take the i-BOXX with me and can work on ball bearings or battery terminals. I usually don't need more than a few additional adapters.“



NEW

1101-1.40-1.12-13 SEPARATOR-PULLER SET

2- and 3-armed, 16-pieces



- > 2 and 3-arm separating and external pullers with self-pressing hooks
- > For pulling tight taper roller bearings, ball bearings, inner races, battery terminals and other thin-walled parts up to a maximum diameter of 70 mm and a maximum installation depth of 125 mm
- > Made in Germany
- > Separating knife usable on both sides
- > The puller can be expanded with additional accessories such as 1.81/10 adapters
- > Can be used flexibly thanks to 2 and 3 arm components
- > With check tool insert for quick identification of missing tools

€414,²⁹
+ VAT

Code	No.	Contents	Max. Usable clamping depth mm	Max. Span mm	Length mm	Width mm	Height mm	Pieces	Weight kg
3437434	1101-1.40-1.12-13	1x 114/104 2 arm truss/head 1x 115/104 3 arm truss/head 3x 112/1-120 puller hooks, complete 2x 1.1406155 spindle complete M14x1.5x155mm 1x 112/0104 2-arm traverse / head 1x 113/0104 3-arm traverse / head 3x 112/02-040 puller hook, complete 2x 1.100660 complete spindle M10x1.5x60mm 1x 1.40/0 separator 5-60 mm 1x 1.38/0 puller 40-120x125mm EI-1101-1.40-1.12-13 CT insert empty 342x262x60mm + 1101 L GEDORE i-BOXX 72, empty	125	90	367	316	72	16	4

2.40

PULLING SET FOR CONSTRUCTION MACHINES

Add-on system, 16 pieces



€703,³⁶ + VAT

- › For the assembly of the robust and handy strap-pattern pulling tools 1.14 and 1.15
- › With this set, you will be able to assemble 10 of the usual flexible strap-pattern pulling tools from the range 1.14/1.15, including the new hydraulic spindle
- › Everything at hand on perforated wall-board

Code	No.	Contents	Pieces	Weight kg
1393030	2.40	1 head 2-armed, No. 114/204 1 head 2-armed, No. 114/304 1 head 3-armed, No. 115/204 1 head 3-arm, No. 115/304 1 spindle SW 19, M18x1.5, 200 mm, No. 1.1806200 1 spindle SW 22, G 1/2", 250 mm, No. 1.2106250 1 Grease hydraulic pressure spindle 10 t, No. 1.06/HSP1 3 puller hooks 210 mm, No. 114/201 3 Pulling hooks 260 mm, No. 114/301 3 puller hooks 390 mm, No. 114/401 6 lugs No. 114/208 12 lugs No. 114/308	16	24.3

1100-1.30

INTERNAL EXTRACTOR SET

in L-BOXX® 136, 8 pieces



€450,⁴² + VAT

- › For inner diameter 12 - 35 mm
- › For extremely-tightly-packed ball bearings, bearing races, bushings, and shaft seals Simmering®
- › With slide hammer and counter support

Code	No.	Contents	Length mm	Width mm	Height mm	Pieces	Weight kg
2836041	1100-1.30	Internal extractor No. 1.30/2.12-15 mm Internal extractor No. 1.30/3.15-19 mm Internal extractor No. 1.30/4.19-25 mm Internal extractor No. 1.30/4A, 25-30 mm Internal extractor No. 1.30/45, 30-35 mm Counter support No. 1.36/1 for 1.30/0 - 1.30/5 Sliding hammer No. 1.35/2, 500 mm, 1.7 kg + GEDORE L-BOXX® 136 No. 1100 L	357	442	151	8	7.2

1.32/2

SET OF INTERNAL AND EXTERNAL EXTRACTORS

15 pieces



€856,³⁰
+ VAT

- > Sets with internal extractors, counter supports, puller chucks, external extractors and stud extractors
- > In robust sheet metal case

Code	No.	Contents	Pieces	Weight kg
8015340	1.32/2	1.30/2 internal extractor 12-15 mm, 1.30/3 internal extractor 15-19 mm 1.30/4 internal extractor 19-25 mm, 1.30/4A internal extractor 25-30 mm 1.30/5 internal extractor 30-35 mm, 1.30/6 internal extractor 35-45 mm 1.30/7 internal extractor 45-55 mm, 1.30/8 internal extractor 55-70 mm 1.36/1 counter support for 1.30/0 - 1.30/5, 1.36/2 counter support for 1.30/6 - 1.30/7 1.19/OXS 3-arm puller XS hook 50x70 mm, 1.12/02 Pole terminal puller 2-armed 60x40 mm 1.06/1 Universal puller, 2 arms, 90x100 mm, 1.06/2 Universal puller, 2 arms, 160x150 mm 1.28/1 stud extractor 6-13 mm, 132/299B tin box empty	15	19

1101-1.29/3K

BALL BEARING EXTRACTOR SET

in i-BOXX® 72, 37 pieces



€595,⁸⁰
+ VAT

- > Ball bearing extractor set for more than 40 ball bearings
- > For removing ball bearings that are both on a shaft and in a housing
- > Non-destructive removal of deep-groove ball bearings without dismantling the shaft; no necessity to drill open the bearing cage (no chippings)
- > With Check-Tool insert for quick check of tool completeness
- > Insert can be used in drawers with minimum dimensions 340 x 260 x 60 mm
- > In GEDORE i-BOXX® 72 No. 1101 L

Code	No.	for ball bearing No.	Contents	Weight kg
2964392	1101-1.29/3K	6000 6001 6002 6003 6004 6005 6006 6007 6008 6009 6010 6011 6012 6200 6201 6202 6203 6204 6205 6206 6207 6208 6209 6210 6211 6212 6213 6300 6301 6302 6303 6304 6305 6306 6307 6308 6309 6310 6311 6403 6404 6405 6406 6407	129/104 Head, 129.106 Spindle SW 14, M10x1.5, 160 mm 129/304 head, 129.306 spindle SW 17, M14x2.0, 210 mm 129/404 head, 129.406 spindle SW 19, M18x2.5, 230 mm 129/504 head, 129.506 spindle SW 22, M20x2.5, 235 mm 129/10 Pulling hook 1 pc. 140 mm (4x) 129/15 Pulling hook 1 pc. 140 mm (4x) 129/25 Pulling hook 1 pc. 170 mm (4x) 129/30 Pulling hook 1 pc. 178 mm with 3 spacers (4x) 129/35 Pulling hook 1 pc. 178mm with 5 spacers (4x) 129/40 Pulling hook 1 pc. 226mm with 5 spacers (4x) 129/45 Pulling hook 1 pc. 226mm with 11spacers (4x) 1.29/0 Plug-in handle burnished EI-1101 CT-1.29/3K Foam insert i-BOXX 72, empty + 1101 L GEDORE i-BOXX 72 empty	5.78

1100-1.41/2A SEPARATOR AND PULLER SET

in L-BOXX® 136, 22 pieces



- › For clamping depths from Ø 22 to 115 mm and clamping reach up to 295 mm
- › Incl. threaded inserts for internal threads M8-M18
- › For loosening and pulling tightly-seated parts e.g. taper roller bearings and inner bearing races

€541,¹⁸
+ VAT

Code	No.	Contents	Max. clamping depth mm	Max. Span mm	Length mm	Width mm	Height mm	Pieces	Weight kg
2927284	1100-1.41/2A	Separator puller No. 1x 1.38/2, 70-215 mm Separator No. 1.40/2, 22-115 mm Set of threaded inserts No. 1.81/20, for 1 and 2-hole applications, M14x1.5 2x extension No. 1.38/CV M14x1.5 + GEDORE L-BOXX® 136 No. 1100 L	295	115	357	442	151	22	11.5

1.81/K-12 THREAD ADAPTOR SET

for 1-hole uses, 11 pieces

€125,²¹
+ VAT



- › The threaded inserts make the removal of threaded caps, possible, when these possess one threaded hole
- › No. 1.81/K-12: With slide hammer No. 1.35/1A, bar 230 mm and impact weight 700 g, adaptor M14x1.5
- › In robust plastic case, 275 x 229 x 83 mm

Code	No.	Contents	Length mm	Width mm	Height mm	Pieces	Weight kg
1936557	1.81/K-12	1.35/1A slide hammer 270 mm, 700 g 181/101 thread insert M10 / M4 181/102 thread insert M10 / M5 181/103 thread insert M10 / M6 181/104 thread insert M10 / M8 181/105 thread insert M10 / M10 181/106 thread insert M10 / M12 181/210 thread insert M14x1.5 / M14 181/211 thread insert M14x1.5 / M16 181/212 thread insert M14x1.5 / M18 135/125-II adapter internal thread M10 - M14x1.5 181/1299 Plastic case with foam insert	270	230	84	11	1.83

1.81/2

THREAD ADAPTOR SET

for 1-hole uses, 6 pieces

- › The threaded inserts make the removal of threaded caps, possible, when these possess one threaded hole
- › No. 1.81/2: For slide hammer No. 1.35/2, 1.36/2, counter support No. 1.36/3



€65,⁹⁶
+ VAT

Code	No.	Contents	Pieces	Weight kg
1120743	1.81/2	181/207 thread insert M14x1.5 / M8, 181/208 thread insert M14x1.5 / M10 181/209 thread insert M14x1.5 / M12, 181/210 thread insert M14x1.5 / M14 181/211 thread insert M14x1.5 / M16, 181/212 thread insert M14x1.5 / M18	6	0.49

1.35/2

SLIDING HAMMER

€76,⁸⁰
+ VAT

- › Suited for the removal of small ball bearings since there is often not enough room for counter-support braces
- › Can also be used with threaded inserts No. 1.81



Code	No.	for internal extractors	Connecting thread	Adaptor	Width across flats mm	Total length mm	Sliding surface	Impact weight in g	Weight kg
8039010	1.35/2	1.30/0 - 1.30/9	M14x1,5	M10	24	520	340	1700	3.03

1.78/5

UNIVERSAL COIL SPRING COMPRESSOR

from

€125,²¹
+ VAT



- › For mounting and dismounting compression springs with a diameter of 110 to 180 mm.
- › For max. spring thickness 13mm
- › Safety note: When the spindles are tightened evenly, the expansion chucks are fixed on the spring coils so that lateral displacement is impossible.
- › VPA-GS-tested safety
- › With safety bracket

Code	No.	Clamping range (min./max.)	Weight kg	excl. VAT
8031380	1.78/S2	60-240	2,2	125,21
8031460	1.78/S3	60-340	2.55	131,09



1.28/4
STUD
EXTRACTOR

€76,⁸⁰
+ VAT



- > For removing damaged studs with right-hand or left-hand thread
- > Even suitable for extremely short stud ends

Code	No.	Diameter, bolt (standing) mm	Width across flats mm	Weight kg
1465031	1.28/4	5-26	19	0.6

1.26/K-3
NUT SPLITTER
SET

6 pieces

€261,³⁴
+ VAT



- > For splitting tight or overtightened nuts without damaging the threaded bolt
- > For nuts up to strength class 6
- > For nuts from size 10 mm (M6) to size 36 mm (M24), including spare chisel
- > With chisel stop
- > In robust plastic case with Check-Tool insert

Code	No.	Contents	Length mm	Width mm	Height mm	Pieces	Weight kg
2017008	1.26/K-3	1 nut splitter for SW 10-17, M6-M10, no. 1.26/1 1 nut splitter for SW 17-24, M10-M16, no. 1.26/2 1 nut splitter for SW 24-36, M16-M24, no. 1.26/3 2 replacement chisels for 1.26/1 + 1.26/2, no. 1.26/M1 1 replacement chisel for 1.26/3, no. 1.26/M3	229	275	83	6	2,46

248 H RECOILLESS HAMMER

- > With hickory handle
- > Splinter-proof, shatter-proof and wear-resistant polyamide heads, 75 Shore D, tested to -20° C



from **€20,83**
+ VAT



Code	No.	Ø	Length mm	Weight kg	excl. VAT
8728220	248 H-25	25	305	0,3	20,83
8868230	248 H-30	30	330	0,47	21,67
8868310	248 H-35	35	335	0,59	22,18
8868580	248 H-40	40	360	0,73	25,29
8868660	248 H-45	45	365	0,87	29,82
8868740	248 H-50	50	370	1,02	32,51

600 H ENGINEER'S HAMMER ROTBAND-PLUS - THE ORIGINAL

- > For universal use in the workshop, on the construction site, in the industrial sector or at home
- > Locksmith's hammer with proven safety technology
- > Hardened and tempered steel hammer head and hardened and tempered steel handle sleeve ROTBAND-Plus
- > Hammer head hot drop forged, DIN 1041
- > Double-curved, durable hickory handle, DIN 5111



from **€15,37**
+ VAT



Code	No.	Head weight g	Stick length mm	Length mm	Weight kg	excl. VAT
8583070	600 H-300	300	305	300	0,502	15,37
8583230	600 H-500	500	320	320	0,727	18,06
8583580	600 H-800	800	350	350	1,135	20,83
8583660	600 H-1000	1000	360	360	1,326	26,21

9 E-5
SLEDGE HAMMER

- > Forged hammer head DIN 1042
- > With ash handle DIN 5135



Code	No.	Weight of head g	Spare handle	Length mm	Weight kg
8612270	9 E-5	5000	E 9 E-5	800	5.535

116 D
PIN PUNCH SET
6 pieces

- > Chrome-vanadium steel
- > Striking heads inductively tempered

€31,67 + VAT



Code	No.	Contents	Length mm	Width mm	Height mm	Pieces	Weight kg
8758050	116 D	119-3 -4 -5 -6 -7 -8	175	110	30	6	0.82

106 D
TOOL SET
6 pieces

- > Vanadium Steel
- > Striking heads inductively tempered

€25,20 + VAT



Code	No.	Contents	Length mm	Width mm	Height mm	Pieces	Weight kg
8725710	106 D	97-125 150 98-125 99 12-3 100-10 119-4	175	112	26	6	0.805

UNIVERSAL
USABLE

119 L
PIN PUNCH SET
6 pieces

€36,¹³_{+ VAT}
€42,99 inkl. MwSt.



- > Vanadium Steel
- > Striking heads inductively tempered
- > Working edge polished and clear varnished
- > In PVC holder

Code	No.	Contents	Length mm	Width mm	Height mm	Pieces	Weight kg
8866290	119 L	119-175-4 175-5 175-6 175-7 175-8 175-10	175	75	16	6	0.58

113 D
DRIFT PUNCH SET
6 pieces

€25,²⁹_{+ VAT}



- > GEDORE Vanadium steel
- > Striking heads inductively tempered

Code	No.	Contents	Length mm	Width mm	Height mm	Pieces	Weight kg
8754060	113 D	99 10-1 2 3, 99 12-4 5, 100-10	175	110	30	6	0.755



A REAL ALL-ROUNDER - PLIERS WRENCHES UP TO 52 MM

The pliers wrench from **GEDORE** is a combination of wrench and pliers in a single tool.

The **183 10 JC pliers wrench** from **GEDORE** is the ideal tool for countless applications in industry, trade and for the DIY'er. The pliers wrench is suitable for holding, pressing, gripping and bending various workpieces, which is what makes the interaction of the mechanics and the smooth jaws possible in the first place. Anyone who works with the pliers wrench can rely on an enormously high pressing and clamping force: the jaws act on the workpiece with more than ten times the manual force.

The smooth and parallel jaws leave no traces on the materials. High-quality surfaces, materials and screw connections are not damaged. Workpieces up to a maximum of 52 mm or 2" can be machined, replacing a whole set of metric and imperial wrenches.

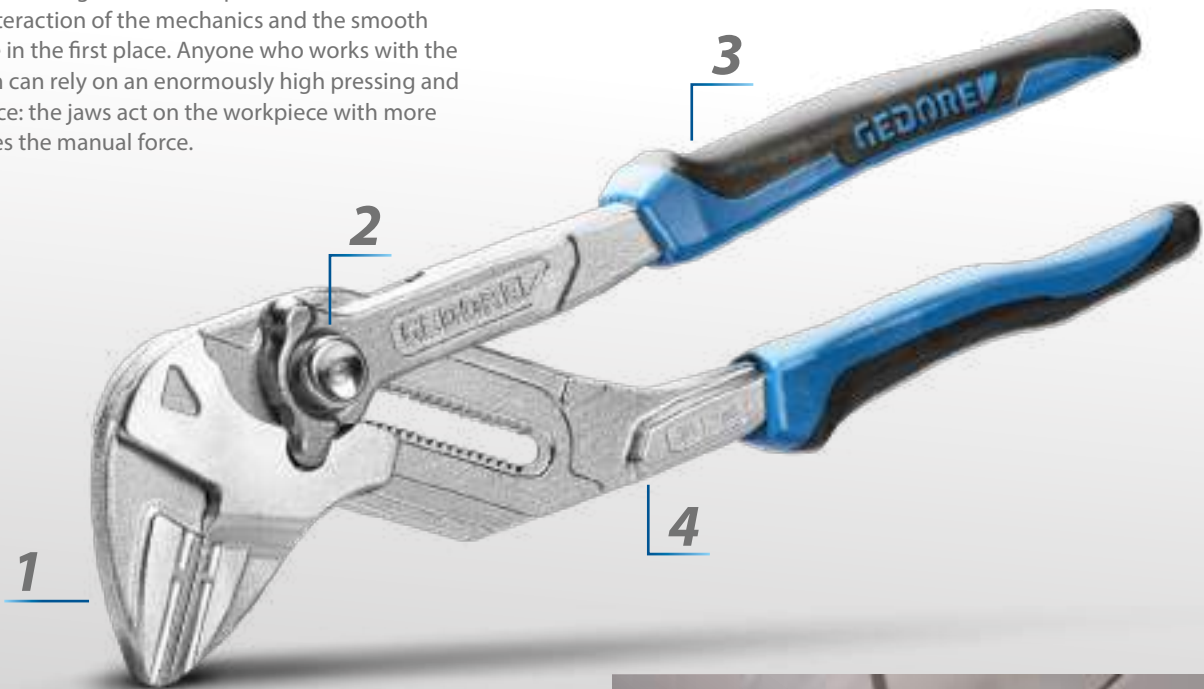

Pliers wrench 183 10 JC

1

HIGH QUALITY ASSEMBLY

- The smooth surfaces of the jaws protect surface-sensitive screw connections or fittings

2

PRODUCTIVE AND EFFICIENT WORK

- The adjustment is made directly on the workpiece using quick adjustment. When working on screw connections, the stroke between the jaws helps and enables fast screwing like with a ratchet

3

THE ALL-ROUNDER

- The pliers wrench is the universal tool for tightening, bending, holding, pressing and gripping

4

HIGH POWER TRANSFER

- The excellent pressing and clamping force with tenfold translation guarantees a firm hold of the workpieces

STRONG GRIP

„The GEDORE pliers wrench is a real universal problem solver for various applications. The pliers wrench grips very tightly and practically without play.“



183 PLIER WRENCH

- > One tool that works like a spanner and pliers
- > Careful assembly of bolt connections with delicate surfaces (e.g. chrome-plated fittings)
- > Perfect for bending, holding, pressing and gripping a wide range of workpieces
- > Sliding mechanism and paralleled jaws for quick and easy adjustment, variable
- > Safe locking of the setting when the size of the opening is selected
- > Sliding mechanism may be activated from almost any setting
- > Protection jaws available as an option



183 10 JC



183 7 TC

from

€37,97
+ VAT

Code	No.	Size	Clamping reach mm	Length mm	Weight kg	excl. VAT
3066029	183 7 TC	7	42	180	0.265	37,97
3066061	183 10 JC	10	52	250	0.575	44,28

142 UNIVERSAL PLIERS



- › Acc. to DIN ISO 8976 Form C
- › With box joint and clamping protection
- › Fine adjustment by push button
- › Push-button one-hand adjustment with large actuating surface
- › Narrow pliers head for hard-to-reach places
- › Long pliers jaws
- › Offset gripping surfaces, self-clamping on nuts and tubes

from **€26,²¹**
+ VAT

Code	No.	Length mm	Head thickness mm	Width of head mm	Clamping width mm	Weight kg	excl. VAT
2668211	142 7 TL	180	6,5	40,0	37	0.183	26,21
6416180	142 10 TL	250	7,5	48,0	38	0.371	27,13
1995413	142 12 TL	300	8,5	55,0	44	0.55	39,74

8248-160 JC ANGLED COMBINATION PLIERS



- › One 60° angled pliers head
- › Specially offset teeth in the grip surfaces for best-possible grip on pipes and screws
- › Optimum use of manual strength, forced hand posture is avoided
- › Induction-hardened precision cutting edges, hardness 63 - 65 HRC
- › For all wires, also hard wire/piano wire, 1.6 mm

€22,⁶⁰
+ VAT

Code	No.	Length mm	Jaw length mm	Head width mm	Tip width mm	Head thickness mm	Weight kg
2276585	8248-160 JC	160	46	24,0	6,0	10,0	0.245

8320-200 JC WIRE ROPE CUTTERS



- › Easy-to-change cutting plates
- › Extremely soft shearing cut reliably prevents the wire rope from fanning out
- › Specially arched cutting edges
- › Hardness 62 - 65 HRC
- › 2 integrated press profiles for Bowden cable end caps and Bowden cable sheath end caps
- › Wire ropes up to 1800 N/mm² with max. 6 mm Ø (e.g. stainless steel wire ropes, wire ropes with steel and textile cables, Bowden cables, shrouds)
- › Wire up to 750 N/mm² with max. 4 mm Ø (e.g. nails/wire pins, screws, bolts, ceiling hangers)
- › Single and multicore copper and aluminium cables with max. 10 mm Ø
- › Adjustable joint for precise cutting plate guidance
- › Latch to prevent unwanted opening

€67,⁸¹
+ VAT

Code	No.	Length mm	Weight kg
2788799	8320-200 JC	200	0.48

100

ELBOW PIPE WRENCH ECK-SCHWEDE-SNAP® - THE SWEDISH

- > Acc. to DIN 5234 Form C
- > High-performance three-point pipe wrench
- > Perfect for work in confined spaces
- > Drop-forged
- > Self-gripping by teeth offset against direction of rotation



from

€90,⁶⁷
+ VAT



Code	No.	Size	Pipe-Ø mm	Length mm	Weight kg	excl. VAT
4500300	100 2	2	80	550	2,24	90,67
4500490	100 3	3	110	630	3,58	143,70

8000 AE CIRCLIP PLIERS FOR EXTERNAL RETAINING RINGS

Form A



from

€17,²²
+ VAT

- > For retaining rings as per DIN 471, DIN 983
- > Straight jaws
- > Inside-positioned opening spring
- > Screwed joint connection



Code	No.	Shaft diameter mm	Shaft diameter "	Total length mm	Length of head	Tip diameter	Weight kg	excl. VAT
2930668	8000 AE 1	10-25	3/8-1	145	39	1,3	0.095	17,22
2923602	8000 AE 2	19-60	3/4-2.3/8	185	57	1,8	0.18	18,98

8000 AE CIRCLIP PLIERS FOR EXTERNAL RETAINING RINGS

Form B



from

€18,⁰⁶
+ VAT

- > For retaining rings as per DIN 471, DIN 983
- > 90° angled jaws
- > Inside-positioned opening spring
- > Screwed joint connection



Code	No.	Shaft diameter mm	Shaft diameter "	Total length mm	Length of head	Tip diameter	Weight kg	excl. VAT
2930706	8000 AE 11	10-25	3/8-1	135	27	1,3	0.095	18,06
2930714	8000 AE 21	19-60	3/4-2.3/8	170	44	1,8	0.18	20,83

8150

CRIMPMAX-360 PROFESSIONAL CRIMPING PLIERS



- › Lightweight, handy crimping pliers, easily operated with minimal hand force and used in hard-to-reach places
- › 360° crimping work area rotatable in 45° increments
- › 4-sided precision crimp over the entire sleeve length, crimping according to DIN 46228 EN50027
- › For ferrules with and without insulating collar up to a length of 18 mm and a cross-section of 0.08 to 16.0 mm² and twin ferrules from 2x 0.25 to 2x 10.0 mm² in only one tool.
- › With automatic cross section adjustment
- › Unlockable ratchet for securing the complete crimping process

€125,²¹ + VAT

Code	No.	Capacity mm ²	AWG	Total length mm	Total width mm	Weight kg
3416437	8150	0,08-16	26-8	193	62	0.45

8151

CRIMPMAX-FLEX PROFESSIONAL CRIMPING PLIERS



- › Flexible tool system, consisting of basic tool and crimp die sets, which can be exchanged quickly and without the need tools
- › Up to 4 different crimp profiles possible with only one insert set
- › For crimping cables with conductor cross-sections up to 16 mm²
- › Ergonomic soft grips with slip guard
- › Positive lock secures the complete crimp

€143,⁷⁰ + VAT

Code	No.	Capacity mm ²	AWG	Total length mm	Total width mm	Weight kg
3416445	8151	0,14-10 0,5-6 0,1-10	26-8 20-10 26-8	220	80	0.51

8158

CRIMP WRENCH

for conductor end-sleeves

€179,⁸³_{+ VAT}

- › Automatic cross section adjustment from 0.08 to 16.0 mm² / AWG 28 - 5 without adjustment
- › Low manual force -30 % reduced compared to the tools known so far
- › Swivel positioner for safe positioning of small cross sections
- › Tool for left and right-handed use
- › Uniform hexagonal precision crimp over the entire length of the sleeve
- › Unlockable ratchet for securing the complete crimping process

Code	No.	Capacity mm ²	Total length mm	Weight kg
2956268	8158	0,08-16	250	0.5

8159

STRIPMAX-ROUND PROFESSIONAL STRIPPING TOOL€16,²⁹_{+ VAT}

- › For convenient stripping of all common round and moisture-proof cables with a diameter of 6.0 - 13.0 mm (e.g. NYM cable 3 x 1.5 mm² to 5 x 2.5 mm²)
- › Automatically regulated cutting depth, therefore also suitable for smaller cable diameters from 6 mm, e.g. 3 x 0.75 mm²
- › The blade arrangement means, no clogging of the galvanized blades by sheath residues possible
- › Length stop integrated in the housing for possible small series or for assembling cables with the same set-off dimensions
- › Durable quality. Robust, glass fibre reinforced polyamide, high quality knife steel from Solingen

Code	No.	Capacity mm ²	Total length mm	Weight kg
3416461	8159	6-13	140	0.048

8154

STRIPMAX-PISTOL PROFESSIONAL WIRE STRIPPER€76,⁸⁰_{+ VAT}

- › Self-adjusting cutting and stripping tool for cross-sections from 0.02 - 10 mm²/AWG 34 - 8. cassette with straight blade
- › Tool-free exchangeable stripping cassettes for a large and versatile stripping capacity
- › Durable integrated cutting function
- › Cutting capacity: Flexible conductors, 10 mm²/ 8 AWG. Rigid conductors, 1.5 mm²/16 AWG
- › Fine adjustment option for removing thin and thick insulation without damaging the conductors

Code	No.	Cable cross-section mm ²	AWG	Weight kg
3416453	8154	0,02 - 10	34-8	0.165

1265 L
TOOL BOX
 5 compartments

- > Great extendability of the tool compartments
- > Great stability even if only one side is opened

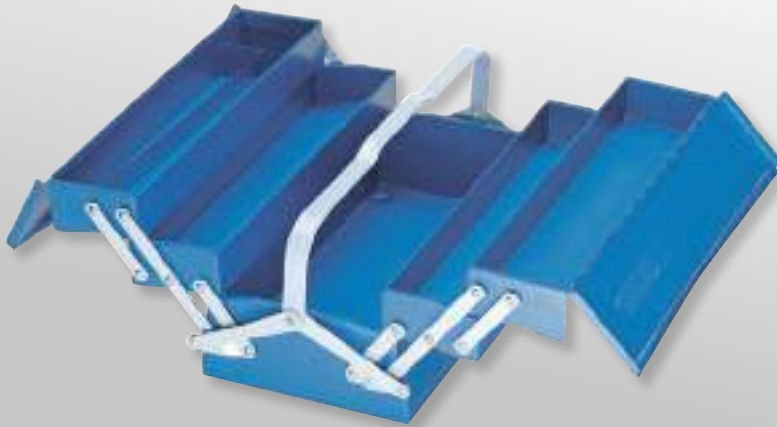

€125,²¹
 + VAT

Code	No.	Width mm	Height mm	Depth mm	Weight kg
6609060	1265 L	420	210	225	5.84

1000
TOOL CASE TOURING
 49 pieces

- > The perfect assortment for most problems
- > In a handy plastic case
- > GEDORE vanadium tools, chrome-plated



€360,⁵⁰
 + VAT



12,5 1/2" mm

Code	No.	Contents	Length mm	Width mm	Height mm	Depth mm	Pieces	Weight kg
6600780	1000	Combination wrench No. 7 6 7 8 10 11 12 13 14 15 17 19 mm 1/2" socket wrench insert 6kt No.19, 10 11 12 13 14 15 17 19 22 mm Extension 1/2" No. 1990-5 -10, 125 250 mm Cardan joint 1/2" No. 1995, 73,5 mm reversible ratchet 1/2" No. 1993 U-20, 270 mm Offset screwdriver set No. PH 42-88, 2-10 mm in holder 8 pcs 3C-Screwdriver slot No. 2150, 4 5.5 6.5 mm 3C-Screwdriver Cross-recess No. 2160 PH 1 2 Voltage tester 220-250 V, slot No. 4615 3, 3 mm Cable knife No. 0513-09, 195 mm Universal Pliers No. 142 10 TL, 10". Power side cutter No. 8316-160 JC, 160 mm 2C handle Multiple Pliers No. 8133-180 JC, 180 mm 2C-Handle Engineer's hammer ROTBAND-PLUS No. 600 H-300, 300 g Percussion tool set No. 106, 6-piece in PVC holder No. 106 + Case WK 1000 L	435	435	100	385	49	7

FOR THE
MOBILE
USE



1100-BASIC
STARTER TOOL KIT
in L-BOXX® 136, 23 pieces

- > Basic equipment for all trades
- > With Check-Tool insert for quick check of tool completeness



€288,24
+ VAT



Code	No.	Contents	Width mm	Height mm	Depth mm	Pieces	Weight kg
2835983	1100-BASIC	L-BOXX® 136 no. 1100 L Assortment no. S1100W-001 Assortment no. 1100 CT2 BASIC	360	152	444	23	6.1

1100-01
GEDORE L-BOXX® 136
WITH CRAFTSMAN ASSORTMENT
 58 pieces

- › Especially suitable for the handyman or do-it-yourselfer
- › A practical assortment for on-site use
- › With Check-Tool insert for quick check of tool completeness
- › GEDORE L-BOXX® 136 with Easy Click connection system



€450,⁴²
 + VAT

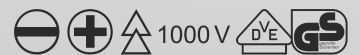

Code	No.	Contents	Width mm	Height mm	Depth mm	Pieces	Weight kg
2658194	1100-01	1/2" reversible ratchet No. 1993 U-20 1/2" extension No. 1990-10, 250 mm 1/2" universal joint No. 1995 1/2" socket wrench insert No. 19, 10 11 12 13 14 15 16 17 18 19 21 22 24 mm Adjustable open-end wrench No. 60 CP 8, 8" Universal Pliers No. 142 10 JC, 10" 2C handle power side cutter No. 8316-160 JC, 160 mm 2C handle Multiple Pliers No. 8133-180 JC, 180 mm 2C handle engineer's hammer No. 600 H-500, 500 g Bricklayer's chisel No. 110-256, 250x16 mm Control cabinet key UNIVERSAL No. 45 S, for control cabinets and locks Miniature LED light No. TFK 649 Hinged base No. E-649 F for LED light No. TFK 649 Cable knife No. 0063-08, blade L. 80 mm Offset screwdriver set No. H 42-10, hexagon 1.3 1.5 2 2.5 3 4 5 6 8 10 mm Offset screwdriver No. SCL 43 TX-80, T9 T10 T15 T20 T25 T30 T40 VDE Screwdriver set No. VDE 2170-2160 PH-077 Slot 2.5 4 5.5, cross recess PH 0 1 2 Voltage Detector Slot No. 4615 3, 220-250 V, 3mm Wooden folding rule No. 4533-2, 2 m Warding file set No. 8728, flat file, triangular, square, half-round, round file + GEDORE L-BOXX® 136 No. 1100 L	444	152	360	58	9.5

ALL GOOD SORTS

1100-02
**TOOL CASE
 ELECTRICIAN**
 in GEDORE L-BOXX® 136,
 36 pieces

€621,⁰¹
 + VAT



- › Especially suitable for professions in electrical engineering
- › A practical assortment for on-site use
- › With Check-Tool insert for quick check of tool completeness



Code	No.	Contents	Width mm	Height mm	Pieces	Weight kg
2658208	1100-02	Bricklayer's chisel No. 110-256, 250x16 mm Electrician's chisel No. 112-2510, 4kt 250x10x7 mm Engineer's hammer No. 600 H-500, 500 g Adjustable open-end wrench No. 60 CP 8, 8" Universal Pliers No. 142 10 JC, 10" Wire stripper No. 8097, automatic Multiple Pliers No.8133-180 JC, 180 mm 2C-Handle VDE side cutter No. VDE 8314-160 H, 160 mm VDE Flat nose pliers No. VDE 8132-200 H, 200 mm VDE Flat Nose Pliers No. VDE 8132 AB-200 H, angled 200 mm VDE Wire stripper No. VDE 8098-160 H, 160 mm VDE cable cutter No. VDE 8094, 200 mm Universal Cable Knife No. 4528, Blade-L. 50 mm Electrical insulating tape No. 4629, tape L.10 m Spatula No. 0175-06, sheet B. 60 mm Offset screwdriver No. H 42-10, hexagon 1.3 1.5 2 2.5 3 4 5 6 8 10 mm VDE Screwdriver set No. VDE 2170-2160 PH-077, slot 2.5 4 5.5 6.5 mm, cross recess PH 0 1 2 Voltage Detector Slot No. 4615 3, 220-250 V, 3mm Voltage Detector Slot No. VDE 4616.12-1000 V, 3 mm Switch cabinet key ELEKTRO No. 45 E Wooden folding rule No. 4533-2, 2 m + GEDORE L-BOXX® 136 No. 1100 L	360	155	36	7.674

1100-1094
VDE TOOL ASSORTMENT
HYBRID
 53 pieces

- > The perfect range of tools for repair and maintenance work on hybrid and electric vehicles
- > Suitable for vehicles of all manufacturers
- > All tools insulated according to EN 60900/EC 60900
- > GEDORE L-BOXX® 136 compatible with the Sortimo® in-vehicle equipment in your service mobile



€629,41
+ VAT

10 3/8 DVE GS 1000 V

Code	No.	Contents	Width mm	Height mm	Depth mm	Pieces	Weight kg
2979063	1100-1094	3/8" VDE socket No. VDE 30, SW 6 8 9 10 11 12 13 14 15 16 17 18 19 20 22 mm 3/8" VDE screwdriver bit No. VDE INX 30, SW 8 10 12 mm 3/8" VDE extension No. VDE 3090 -3 -6, 75 150 mm 3/8" VDE reversible ratchet No. VDE 3093 U VDE slotted screwdriver no. VDE 2170, 2.5 3.5 4 5.5mm VDE screwdriver Phillips No. VDE 2160 PH 1 2 3 VDE screwdriver TX no. VDE 2163 TX T20 T25 T30 VDE cable shears no. VDE 8094, 200mm VDE universal pliers no. VDE 146 10, 10" VDE power combination pliers no. VDE 8250-200H, 200mm 2K handle VDE power side cutters no. VDE 8314-180H, 180mm VDE needle nose pliers no. VDE 8132 AB-200 JC, 200 mm angled 2K handle VDE flat nose pliers no. VDE 8120-160H, 160mm 2K handle VDE cable knife no. VDE 4522, 180mm Meter grommet no. V 914, size 1 2 3 + GEDORE L-BOXX®	444	152	360	53	8.28

VDE 2170-2160 PH-077 VDE SCREWDRIVER SET

7 pieces

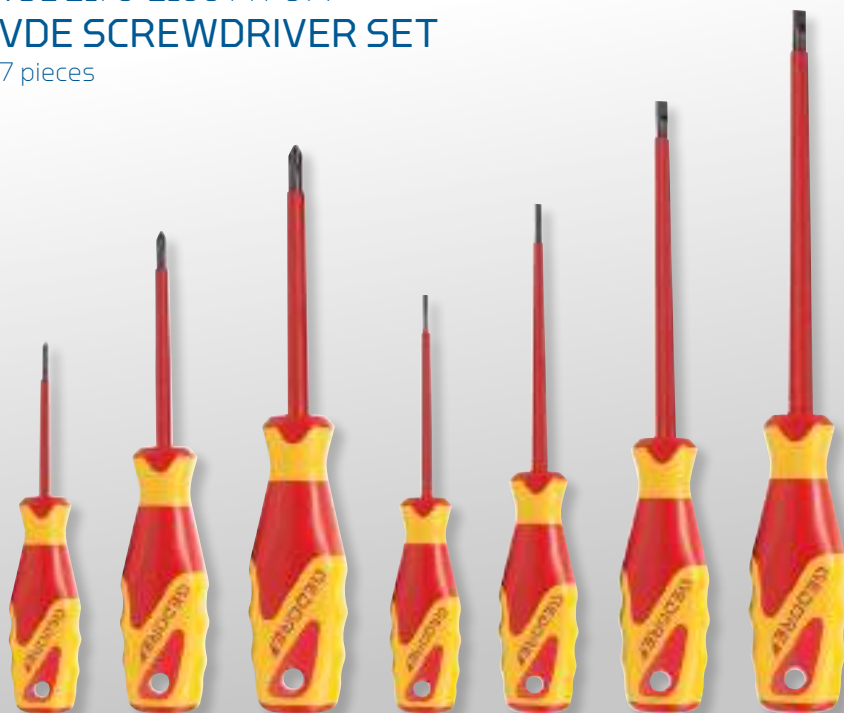

- › Drive shape and size marking at the end of the handle
- › Protective insulation up to 1000V AC according to DIN EN/IEC 60900, fully insulated blade
- › Ergonomic handle shape for precise, fatigue-free work
- › Positive connection of handle and blade for optimum power transmission
- › Blade from molybdenum-vanadium-Plus tempered steel

€49,⁷⁴_{+ VAT}



Code	No.	Contents	Pieces	Weight kg
1616048	VDE 2170-2160 PH-077	VDE 2170 2,5 4 5,5 6,5 mm, VDE 2160 PH 0 1 2	7	0.575

VDE 4508 VDE TORQUE WRENCH

5-25 Nm - 10-50 Nm



- › Perfect for electronics technicians, electricians, control cabinet construction, line clamping (skilled electrician)
- › Proven release system from the Torcofix series generates a tactile and audible release signal
- › Scale with Nm graduation, values can be set to an accuracy of 0.25 Nm
- › Classified according to DIN EN ISO 6789-2:2017 Type II Class A, incl. traceable test certificate, calibrated to a maximum permissible deviation of +/- 3% and thus more precise than the +/- 4% required by the standard
- › Recalibration and adjustment without destroying the insulation
- › Fine toothed ratchet with square drive as per DIN 3120, ISO 1174
- › Safety button to protect against accidental release of the insert
- › Large controls allow adjustment and operation with gloves, ergonomic, durable
- › VDE insulation up to 1000 V, acc. to EN 60900/IEC 60900

from

€343,⁷⁰_{+ VAT}



Code	No.	Type	Square drive inch	Square drive metric mm	Nm	Nonius	Height mm	Housing - square centre spacing mm	Length mm	Head width mm	Head height mm	Weight kg	excl. VAT
3125335	VDE 4508-02	Reversible ratchet	3/8"	10	5-25	1	75	24	319	50,0	62	0.714	343,70
3079066	VDE 4508-05	Reversible ratchet	1/2"	12,5	10-50	2,5	80	24	369	48,0	62	0.825	360,50

SIX VDE SCREWDRIVERS WITH AN EXTRA SLIM BLADE

If a screw is deep and cannot be grasped by conventional screwdrivers, the SLIM DRIVE is used and impresses with its ultra-slim blade diameter.

The **SLIM DRIVE VDE 2162-2172 PM-06 VDE** screwdriver set from **GEDORE** consists of VDE slotted screwdrivers in sizes 3.5 4 5.5 and VDE Phillips screwdrivers in sizes PH 1 and 2 and SL PH 2. With an extremely small blade diameter, the screwdrivers in the SLIM DRIVE series effortlessly reach screws in deep screw shafts. They are VDE-insulated up to 1,000 volts and meet all the requirements of DIN EN 60900:2013-04 for safe

working under electrical voltage. The ergonomic 3-component Power Grip³ prevents wrist fatigue and is positively connected to the blade to ensure optimal power transmission.

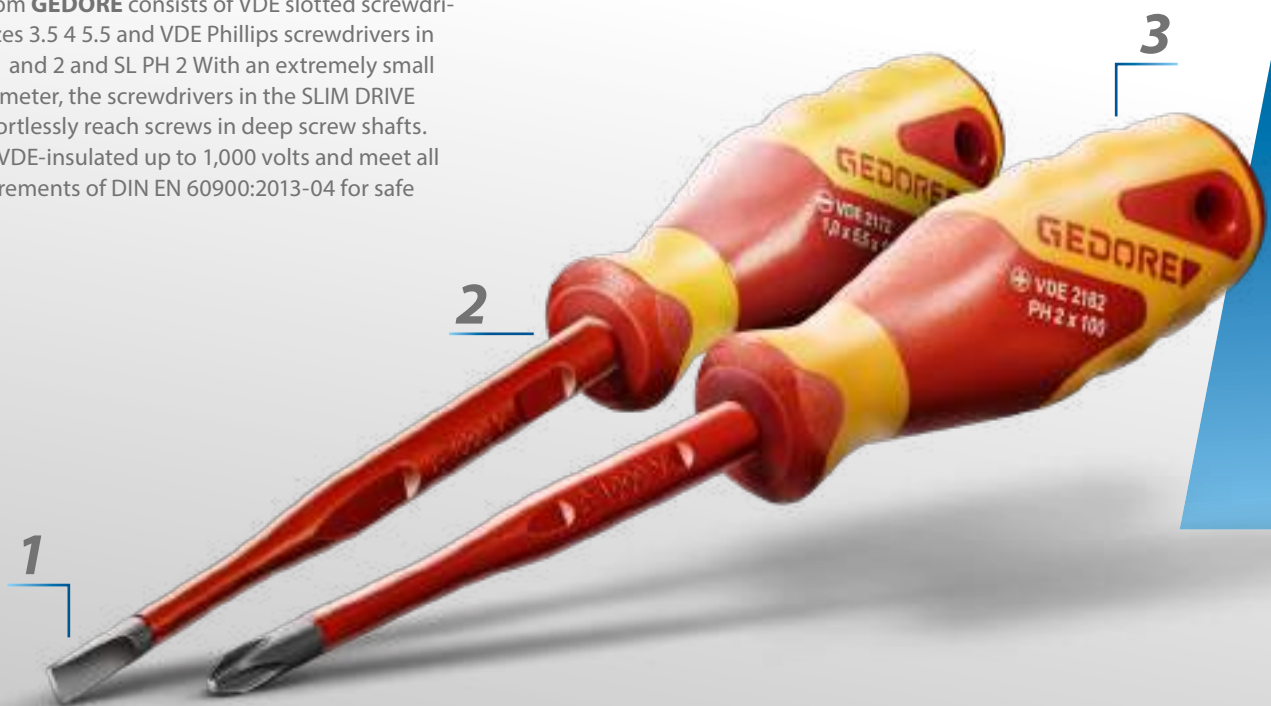

VDE Screwdriver Set SLIM DRIVE 6 pieces VDE 2162-2172 PM-06

VDE 2162-2172 PM-06 VDE SCREWDRIVER SET SLIM DRIVE

6 pieces



- > For slotted, cross-head PH and plus-minus screws
- > Ultra-small blade diameter yet with full mechanical and electrical safety
- > Insulated up to 1000 V, according to EN 60900/IEC 60900, fully insulated blade
- > Ergonomic 3-component Power-Grip³ handle for maximum power transmission with minimum strain on the hand
- > With hanging hole on the handle for space-saving storage

€45,²⁰_{+ VAT}



Code	No.	Contents	Pieces	Weight kg
2928701	VDE 2162-2172 PM-06	VDE 2172 3,5 4 5,5, VDE 2162 PH1 2, VDE 2164 SL/PH2	6	0,59

1

INNOVATIVE

- Easy and protected access to deep-lying screws thanks to the ultra-small blade diameter

2

OPTIMUM POWER TRANSMISSION

- The positive connection between the 3-component handle „Power Grip³“ and the blade ensures high power transmission and torque

3

EFFICIENT WORK

- The roll-off protection and the labeling of output and size at the end of the handle ensure fast and efficient work



CUSTOM-FIT
AND SAFE UP
TO 1000 VOLTS



„Perfect fit, even if the screw head is not ideal, very good grips with high power transmission.“

VDE 2162-2172 PZ-06 VDE SCREWDRIVER SET SLIM DRIVE

6 pieces

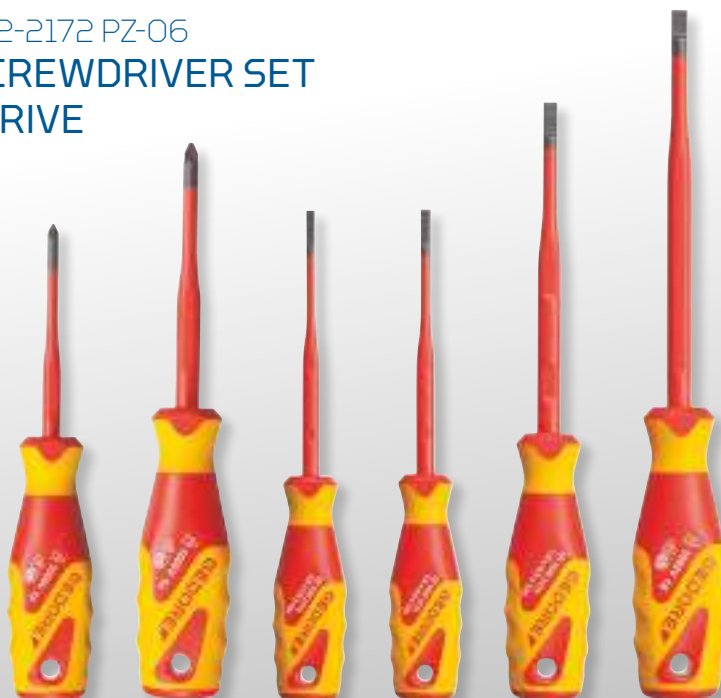

- › For slotted and cross-head screws PZ
- › Ultra-small blade diameter yet with full mechanical and electrical safety
- › Insulated up to 1000 V, according to EN 60900/IEC 60900, fully insulated blade
- › Ergonomic 3-component Power-Grip³ handle for maximum power transmission with minimum strain on the hand

€43,³⁵
+ VAT



Code	No.	Contents
2928728	VDE 2162-2172 PZ-06	VDE 2172 3,5 4 5,5 6,5, VDE 2162 PZ 12

Pieces	Weight kg
6	0.59

VDE 8131 AB-200 H VDE MULTIPLE PLIERS

with VDE insulating sleeves,
angled pattern



- › Pliers in VDE design especially adapted to the needs of electricians
- › Cable cutter, cables up to 5x2.5 mm² or Ø 12 mm
- › Stripping blades for wires 1.5 mm² and 2.5 mm²
- › Crimping profile: Crimping of ferrules
- › Serrated gripping surface
- › Curved pliers tip
- › Protective insulation up to 1000 V, according to EN 60900/IEC 60900
- › Envelope insulation



Code	No.	Total length mm	Weight kg
2910845	VDE 8131 AB-200 H	200	0.217

VDE 8092-160 H VDE CABLE SHEARS



- › For cutting multi-core copper and aluminium cables up to max. 50 mm² or up to a Ø of 10 mm
- › Handles with VDE insulating sleeves up to 1000 V, acc. to EN 60900/IEC 60900
- › Precision ground for optimum action, new cutting-edge geometry
- › Not suitable for steel wire and hard-drawn copper conductors
- › Hardness 55 HRC
- › Special hardened and tempered steel, forged, ground, with dipped handle protection

Code	No.	Cable cross-section mm ²	Wire/cable diameter	Total length mm	Total length inch	Weight kg
3412407	VDE 8092-160 H	50	10	169	6 2/3"	0.21

VDE 8314-180 H VDE POWER SIDE CUTTER

with VDE insulating sleeves



- › With slim head, ideal for tight spaces for cutting medium-hard wire 1.6 mm and copper/plastic 4 mm
- › Capacity max. 13 mm/5x2.5 mm²
- › Wire up to 16 mm²/AWG 5
- › Induction hardened precision cutting edges, cutting edge hardness 63-65 HRC
- › GEDORE special hardened and tempered steel, chrome-plated
- › Protective insulation up to 1000V AC according to DIN EN/IEC 60901



Code	No.	Length mm	Jaw length mm	Jaw width mm	Head thickness mm	Ø	Weight kg
2910950	VDE 8314-180 H	180	25	26,0	11,0 mm	1,6	0.297

VDE 8250-180 H VDE HEAVY DUTY COMBINATION PLIERS

with VDE insulating sleeves



€25,²⁰
+ VAT

- › Good lever action for easy cutting
- › Induction-hardened precision cutting edges, hardness 62 - 64 HRC
- › For all wire types including piano wire, 1.6 mm
- › Serrated gripping faces
- › High cutting performance with guaranteed 35% less effort
- › Legs VDE insulated up to 1000 V, according to EN 60900/IEC 60900, 2-component handle protection sleeves



Code	No.	Length mm	Jaw length mm	Head width mm	Tip width mm	Head thickness mm	Weight kg
1550950	VDE 8250-180 H	180	38,5	25,6	6,5	11,0	0.288

VDE 8132-200 H 200 VDE TELEPHONE PLIERS

with sheath insulation, straight

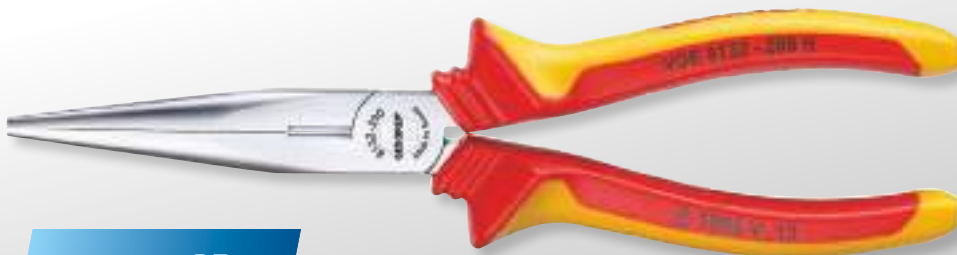

€27,¹³
+ VAT

- › Long, flat-round jaws, straight gripping faces, serrated
- › For holding, gripping, bending and cutting
- › Protective insulation up to 1000 V, according to EN 60900/IEC 60900
- › Envelope insulation



Code	No.	Total length mm	Jaw length mm	Width of head mm	Width of centres mm	Head thickness mm	Thickness of point	Weight kg
1552120	VDE 8132-200 H	200	75,7	18,5	3,7	9,5	2,8	0.235

VDE 8132 AB-200 H VDE TELEPHONE PLIERS

with VDE insulating sleeves,
angled pattern



€27,¹³
+ VAT

- › Long, flat-round jaws, straight gripping faces, serrated
- › Tips 45° angled
- › Protective insulation up to 1000 V, according to EN 60900/IEC 60900
- › Envelope insulation



Code	No.	Total length mm	Jaw length mm	Width of head mm	Width of centres mm	Head thickness mm	Thickness of point	Weight kg
1552147	VDE 8132 AB-200 H	200	70,5	18,5	3,7	9,5	2,8	0.235

ADJUSTABLE VDE PLIERS WRENCH UP TO 50 MM

Work on refined or very sensitive surfaces can be carried out without damaging the material.

The **VDE pliers wrench VDE 183 10** from **GEDORE** is ideally suited for use in the electronics sector. It easily masters holding, pressing, gripping and bending various workpieces up to a width across flats of 50 mm or 2". The VDE pliers wrench from **GEDORE** replaces two complete wrench sets, metric and imperial. Anyone who works with the pliers wrench can rely on an enormously high pressing

and clamping force: the jaws act on the workpiece with more than ten times the manual force. The smooth and parallel jaws leave no traces on the materials. High-quality surfaces, materials and screw connections are not damaged.

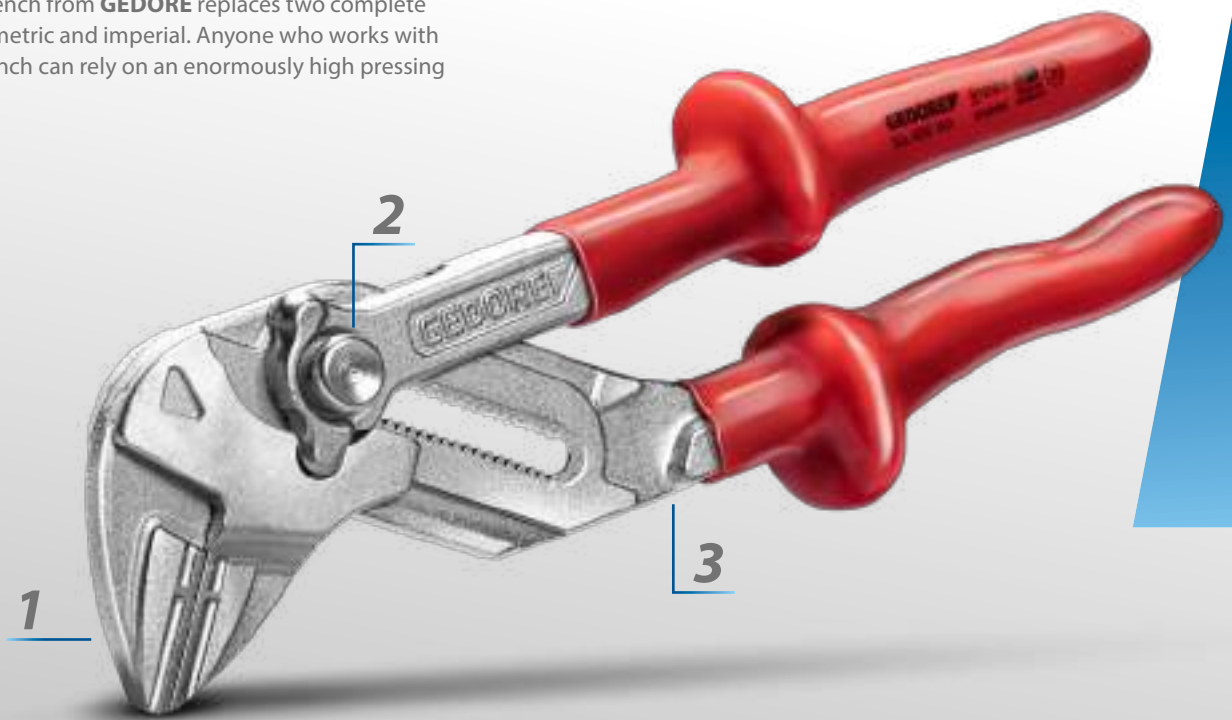

VDE Pliers wrench VDE 183 10

VDE 183 10 VDE-PLIER WRENCH



- > Adjustable, universal tool for wrenching work, bending, holding, pressing and gripping
- > Smooth jaws for gentle gripping of surface-sensitive workpieces (e.g. chrome-plated screw connections, bathroom fittings)
- > Function of an open-end ratchet
- > Unique functional jaw holder, e.g. for protective jaws
- > 21 setting positions and quick adjustment with automatic engagement function
- > Protective insulation up to 1000 V, according to EN 60900/IEC 60900, 2-fold Check-Tool insulation
- > DIN ISO 5743/IEC 60900



Code	No.	Size	Clamping reach mm	Length mm	Weight kg
3066088	VDE 183 10	10"	50	250	0.665

1

GENTLE ON SURFACES

- No damage to surface-sensitive screw connections (e.g. chrome-plated fittings) thanks to smooth and parallel jaws

2

QUICK AND EASY ADJUSTMENT

- The wrench size can be set quickly and easily using the sliding mechanism (0-50 mm or 0-1.7/8")

3

DIVERSE APPLICATIONS

- Thanks to the ingenious mix of wrench and pliers, the pliers wrench replaces 3 products
- Thanks to the ratchet function, the pliers wrench can carry out a wide range of applications, depending on the size



VDE UNIVERSAL TOOL

„Indispensable for me in the electronics sector. The pliers wrench simplifies work processes immensely.“

VDE S 8003 H VDE PLIERS SET

with sheath insulation, 3 pieces

€63,²⁷ + VAT



- › Practical set composition in environmentally-friendly cardboard box
- › Envelope insulation



Code	No.	Contents
1550594	VDE S 8003 H	VDE 8132-160 H, VDE 8250-180 H, VDE 8314-160 H

Pieces	Weight kg
3	0.747

HANDY TRIO - VDE PLIERS SET FOR ALL ELECTRICAL WORK

VDE pliers set 1102-005 VDE: The three most important VDE tools in one set for all work on live workpieces.

precision cutting edges. All 3 tools are VDE-insulated up to 1,000 volts - and meet all the requirements of DIN EN 60900:2013-04 for safe working under electrical voltage.

VDE screwdriver PZ 1, needle-nose pliers and side cutters – three all-rounders that belong in every tool box, housed as **VDE pliers set 1102-005 VDE** in the practical L-BOXX. The VDE screwdriver is equipped with an ergonomic 3-component Power Grip³ for precise, fatigue-free work. The handle and the blade are positively connected to each other, so that an optimal power transmission is guaranteed. The VDE needle nose pliers and the VDE side cutter complete the set. Both have an ergonomic 2K handle and inductively hardened



VDE-Pliers-Set 3 pieces in L-BOXX Mini 1102-005 VDE

1102-005 VDE VDE PLIERS SET

3 pieces

€72,²⁶_{+ VAT}



- > Insulated up to 1000 V, according to EN 60900/IEC 60900
- > Envelope insulation
- > With VDE Impact diagonal cutter and VDE multiple nose pliers
- > With SLIM DRIVE VDE screwdriver for PZ Phillips screws
- > In GEDORE L-BOXX® Mini, including range of dividers



Code	No.	Contents	Length mm	Width mm	Height mm	Pieces	Weight kg
2951762	1102-005 VDE	VDE 8314-180 H, VDE 8131 AB-200 H, VDE 2162 PZ 1	157	260	63	3	0.955

1

PRECISE, TOP-QUALITY CUTTING

- The cutting edges of the diagonal cutters and the needle nose pliers are inductively hardened and therefore extremely durable

2

PLIERS WITH ERGONOMIC HANDLES

- The ergonomic 2K handles on the side cutter and long-nosed pliers are made for long-term, comfortable use

3

OPTIMUM POWER TRANSMISSION WHEN SCREWING

- The positive connection between the 3-component handle „Power Grip“ and the blade ensures high power transmission and torque with the VDE screwdriver SLIM

4

COMPLETE SECURITY FOR ALL ELECTRICAL WORK

- All three tools are insulated up to 1,000 volts and meet the requirements of DIN EN 60900:2013-04



VDE MUST-HAVES TOOLS



„With the set as original equipment, you are optimally positioned. The quality of the VDE tools is top. The tools are not only very comfortable to hold, they are also precisely machined on the cutting edges and blades. That’s where you can see absolute top quality!“

1102-006 VDE VDE TOOL SET

4 pieces

€90,⁶⁷
+ VAT



- › Insulated up to 1000 V, according to EN 60900/ IEC 60900
- › For all usual electric master cabinets incl. multi fitting key
- › In GEDORE L-BOXX® Mini, incl. divider set



Code	No.	Contents	Width mm	Height mm	Depth mm	Pieces	Weight kg
2951770	1102-006 VDE	VDE 8131 AB-200 H, VDE 2172 3,5, VDE 2164 SL/PH 2, 45 E	260	63	155	4	0.86

KL-1000-20 A
KING PIN PRESS 65T



- › Designed for the quick and professional pressing out/pressing in of king pins as found on HGVs.
- › The king pin press with its adjustable press frame has been developed and adapted to satisfy the latest safety requirements. Thanks to its compact and ingenious design, the king pin press not only saves a lot of time but also allows for easy and, above all, safe operation.
- › The heavy-duty 65t hydraulic cylinder with integrated hand pump and the pneumatic quick-stroke 'extend/retract' valve enable even severely seized king pins to be extracted with ease.

Advantages:

- › One-person operation.
- › Developed according to the newest safety requirements.
- › Universally usable, on the vehicle as well as free-standing.
- › High time saving.
- › Universally adjustable press frame that can be turned 180°.
- › Easy and quick positioning on the vehicle due to the quick adjustment with three axes.

€5295,⁰⁰ + VAT



Code	No.	Total swivel angle	Press force	Stroke	Air connection (max.)	Nominal pressure	Width, inside (press frame) mm	Length, inside (press frame) mm	Weight kg
3091600	KL-1000-20 A	180°	65	120	13	420	290	480	130

LARGER STATE ROOM



KL-4007-411 SWIVEL HANDLE 3/4"

- › Extra long design (980mm), with 180° swivel head.
- › Ideal for loosening extremely tight/stuck screws.



€110,⁸⁰
+ VAT

3/4"

Code	No.	Drive connector square	Total swivel angle	Load (max.) Nm	Total length mm	Weight kg
2941554	KL-4007-411	3/4"	180°	1.050	980	3.5

KL-1072-100 BRAKE CALIPER LIFTING DEVICE

- › The brake calliper lifting device enables easy and back-friendly lifting at a precise angle of heavy brake callipers of commercial vehicles and trailer axles with the aid of a workshop crane and without the assistance of a second person.
- › Advantageous e.g. when disassembling and assembling the brake calliper.



€382,²⁶
+ VAT

Code	No.	Load (max.) kg	Number of setting positions	Weight kg
3415589	KL-1072-100	75	8	2.1

KL-4999-420

WORKSHOP TROLLEY

with commercial vehicle hand tool assortment,
302 pieces

- › Extensive range of commercial vehicle/agricultural machinery trolley with tools for professionals
- › Tools in metric version
- › Fully extending wide drawers
- › Large usable storage space with shelf and door
- › Central locking with cylinder lock
- › Each drawer has built in safety locking feature, easy single-hand operation
- › Total load capacity 1000 kg, in mobile operation 750 kg
- › Load capacity per drawer 70 kg



€5000,00
+ VAT



Code	No.	Height mm	Width mm	Depth mm	Static load carrying capacity kg	Load capacity kg	Number of drawers	Pieces	Weight kg
3418367	KL-4999-420	985	1.200	635	1000	750	6	302	220

Contents

- 1/4" assortment (SW 4-13, IN 4-8, and T8-T25)
- 1/2" assortment (SW 10-32, T20-T60 long, IN 6-19 and IN long 6-14, power screwdriver sockets SW 17-32, and telescopic ratchet)
- 3/4" assortment (SW 21-60, E24, and IN long SW 14, and power screwdriver inserts SW 24-41)
- Bit set and ratchet screwdrivers
- Screwdriver sets (slot 4.5-8, PH 1-4, T10-T40, and IN 2-10)
- Spanner sets (SW 6-41 + brake line and starter block spanners)
- Impact spanner sets (E18/E20/E24, hexagon SW 24/26/27, and hexagon SW 19/21/24)
- Extensive range of pliers, Extensive range of impact and hand lever tools
- Extensive range of measuring, cutting, and machining tools

KL-1020-41 A
**6-PIN LOCK NUT SOCKET
 WITH GUIDING TUBE**
 3/4"

€432,¹²
 + VAT

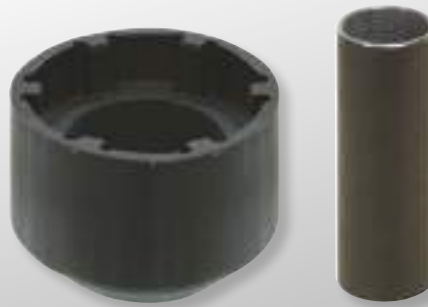

- › Ideal for loosening and tightening lock nuts as found on front and rear axles.
- › Allows base tool and guide tubes to be combined universally. (observe connection thread)

Advantages:

- › Substantial time and cost savings.
- › Universal application.

Code	No.	Drive connector square female	Number of studs	Journal width	Outer Ø, guide tube mm	Outer diameter	Diameter milled slot of piston rod	Weight kg
2691809	KL-1020-41 A	3/4"	6	11,6	66,5	147	117	7.5

KL-1005-100 A Z
**WHEEL HUB PULLER KIT,
 MECHANICAL**
 mechanical

€1265,⁴⁹
 + VAT



- › This wheel hub puller kit allows you to professionally pull the wheel hub off the drive axle.
- › The removal of the wheel hub takes place via the wheel studs.
- › The different pressure pieces are used to provide central support via the axle tube.

Code	No.	Width, inside (press frame) mm	Length, inside (press frame) mm	Wheel stud circles	Drive type	Weight kg
3418588	KL-1005-100 A Z	178 bis 320	152	8x275 mm 10x335 mm	mechanical	26

KL-1005-111 Z
WHEEL HUB PULLER

€1080,³⁰
 + VAT



- › The wheel hub puller permits professional removing of wheel hub/bearing units with removable hub caps.
- › After the hub cap has been removed, the unit is removed via the threaded holes on the hub or, in the case of low-loaders, via the wheel bolts on the wheel hub.
- › Support is provided centrally via the axle tube, using the different thrust discs.
- › The special adapter plate offers universal adaptation to a large number of bolt hole circles that are available on the market.

Code	No.	Wheel stud circles	Drive type	Weight kg
3418596	KL-1005-111 Z	10x120mm 10x122mm 10x143mm 10x165mm 10x168mm 12x144mm 12x145mm 12x164mm 12x168mm 14x138mm 14x144mm 10x225 mm	mechanical	21.5

KL-1000-0115 RETAINING TOOL FOR WHEEL HUBS



€310,²⁴
+ VAT

- › The holding device enables the wheel head (wheel hub) to be counterheld professionally via the wheel studs.
- › Required e.g. for loosening and controlled torque tightening of the wheel bearing, quick-release axle, and brake disc bolts, as well as the wheel capsule.
- › Particularly suitable also when using with the KL-1005-1.. - wheel hub puller series., in conjunction with the mechanical drive kit.

Code	No.	Length, swivel arm mm	Bore Ø mm	Length mm	Weight kg
3413195	KL-1000-0115	315	23	990	4.4

KL-1029-300 WHEEL HUB LIFTING TOOL



€99,⁷²
+ VAT

- › The wheel hub lifting tool enables easy and back-friendly lifting of heavy wheel hubs of commercial vehicle and trailer axles with the aid of a workshop crane and without the assistance of a second person.
- › The lifting tool can be infinitely adjusted to keep the wheel hub exactly in balance.
- › Advantageous e.g. for disassembling and assembling the wheel hub as well as for changing brake discs.

Code	No.	Load (max.) kg	Bore Ø mm	Adjustment range	Weight kg
3413071	KL-1029-300	300	23	110	1.1

KL-1005-800 MECHANICAL DRIVE SET



€254,⁸⁴
+ VAT

- › The drive set enables the simple mechanical drive of the NFZ wheel hub remover sets KL-1005-100 A as well as KL-1005-111.
- › In combination with the pressure spindle 1.3306500, available as an accessory, it can also be used on the NFZ press frame KL-1039-111

Code	No.	Drive type	Drive connector hexagon male (metric)	Spindle total length	Spindle Thread length (usable) mm	Weight kg
3412881	KL-1005-800	mechanical	36,0	400	310	3.5

KL-1039-111 Z

HGV PRESS FRAME, MECHANICAL

(mechanical)



- › The large and massive commercial vehicle press frame makes it possible to remove and install a wide variety of bushings, bearings or bolts directly on the vehicle.
- › For example, on extension arms, tippers, deposit tippers, lifting arms, hook lift systems, chassis parts and much more.
- › With additional pressure/support sleeves from the KL-0039 Series this can easily be supplemented with further diameters.
- › The bearing base included in the scope of delivery also allows the mobile NFZ press frame to be placed e.g. on a workbench, as well as for stationary use as a light-weight stand press for on the road, e.g. in commercial vehicle service or repair vehicles.
- › The length and width of the NFZ press frame can also be quickly adjusted using the extension rods and the holes in the base plates.

€2326,⁸⁰ + VAT

Code	No.	Drive type	Load (max.) t	Width, inside (press frame) mm	Width, inside (press frame) mm	Width, inside (press frame) mm	Length, inside (press frame) mm	Length, inside (press frame) mm	Weight kg
3418618	KL-1039-111 Z	mechanical	28	180	250	320	500	700	51

KL-1039-1111

PRESS FRAME 28 T

(without bridge from KL-1005-100 A)



- › The large and massive commercial vehicle press frame makes it possible to remove and install a wide variety of bushings, bearings or bolts directly on the vehicle.
- › For example, on extension arms, tippers, skip loaders, lifting arms, hook lift systems, chassis parts and much more.
- › With additional pressure/support sleeves from the KL-0039 series, this can easily be supplemented with further diameters.
- › The mounting foot included in the scope of delivery also allows the mobile commercial vehicle press frame to be placed on a workbench, for example, as well as for stationary use as a light-weight standing press when on the road, for example in commercial vehicle service or repair vehicles.
- › The length and width of the commercial vehicle press frame can also be quickly adjusted using the extension rods and the holes in the base plates.

€1408,⁷⁴ + VAT

Code	No.	Drive type	Load (max.) t	Width, inside (press frame) mm	Width, inside (press frame) mm	Width, inside (press frame) mm	Length, inside (press frame) mm	Length, inside (press frame) mm	Weight kg
3275280	KL-1039-1111	mechanical hydraulic	28	180	320	250	500	700	34

KL-1001-251 A
SILENTBLOC TOOL

› The KL-1001-251 A sleeve set allows for the quick and easy removal and replacement of HGV trailer drawbar silentblocs.

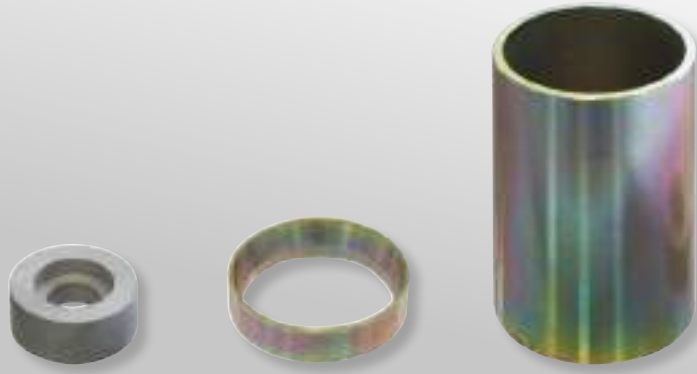

€83,10
+ VAT

Code 2546507	No. KL-1001-251 A	Drive type hydraulic	for outer Ø, fitted mm 57	Weight kg 1.4
------------------------	-----------------------------	--------------------------------	-------------------------------------	-------------------------

KL-1023-2085
HUB CAP AND AXLE NUT SOCKET

hexagon, a/f 85

› This tool allows for the professional loosening and tightening of hub caps/ axle nuts.



€188,36
+ VAT

Code 3036367	No. KL-1023-2085	Drive connector hexagon male mm 36,0	Width across flats mm 85	Weight kg 1.8
------------------------	----------------------------	--	------------------------------------	-------------------------

KL-1023-2095
WHEEL CAPSULE AND
AXLE NUT SOCKET 3/4"

octagonal

› This tool allows for the easy and professional loosening and tightening of hub caps and axle nuts.

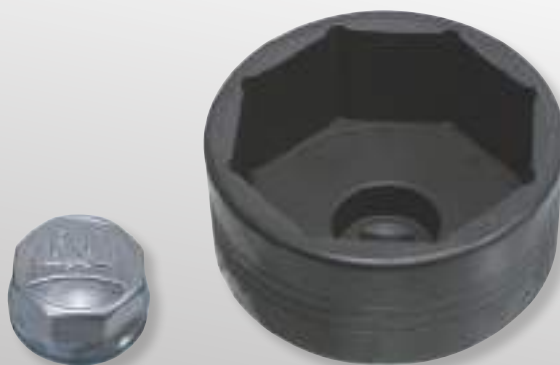

€188,36
+ VAT

Code 2451913	No. KL-1023-2095	Drive connector square female 3/4"	Profile square	Width across flats mm 95	Weight kg 2.3
------------------------	----------------------------	--	--------------------------	------------------------------------	-------------------------

KL-1023-4X
SOCKET 1"
 bi-hex for axle nuts

› This tool allows for the professional loosening and tightening of wheel capsules/axle nuts.



from

€282,54
 + VAT



Code	No.	Drive connector square female	Profile	Width across flats mm	Length mm	Weight kg	excl. VAT
3135853	KL-1023-4085	1"	bi-hexagon	85	75	2.3	288,08
3221199	KL-1023-4095	1"	bi-hexagon	95	75	2.7	282,54

KL-0041-800
WHEEL BEARING TOOL KIT
 Iveco Daily

› Used in conjunction with an appropriate workshop press, the KL-0041-800 wheel bearing tool set allows for the quick and professional removal and installation of wheel hubs as well as wheel bearing units on the front axle of Iveco Daily vehicles.

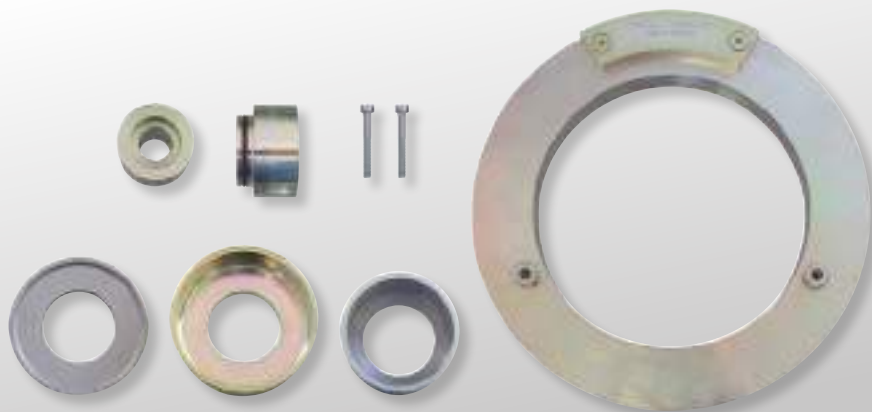

€426,58
 + VAT

Code	No.	Load (max.) kg	Suitability	Weight kg
3087263	KL-0041-800	17000	Iveco	10.3

WWW.GEDORE.COM



TOOLS FOR AGRICULTURE

**AGRICULTURAL VEHICLES
ARE PERMANENTLY EXPOSED TO EXTREME
AND ENVIRONMENTAL INFLUENCES.**

Repairs and maintenance must be carried out efficiently and quickly as possible, especially during harvesting and at the same time meet the highest safety standards.

The right tool - for standard or special applications - is the basis for smooth processes. The new GEDORE agricultural portfolio, specially tailored to these requirements, offers the right solution for every challenge. Whether you need to fix corroded bolts, work in hard-to-reach places or replace and repair sensitive components - with the new GEDORE agricultural portfolio, you can solve maintenance and repair challenges simply, quickly and efficiently maintenance and repair challenges simply, quickly and safely.

You will find an exclusive selection of our agricultural products now also in the new „**AGRAR-Selection**“ or online at www.gedore.com/agriculture-tools

NEW



SAFE WORK PROCESSES WITH GEDORE

Both standard and special tools are developed to the highest technological standards and ensure safe and efficient working results for users worldwide. As in all areas of application, GEDORE also focuses on occupational safety in agriculture. That is why our tools are designed in such a way that, for example, in the event of unintentional incorrect loading of spanners, the tool will bend and not break.

Whether for repairs or maintenance work tractor, combine harvester, baler, potato harvesters or drum mowers - tools from GEDORE stand for fast and safe work processes.

*POWERFUL
AND ROBUST*

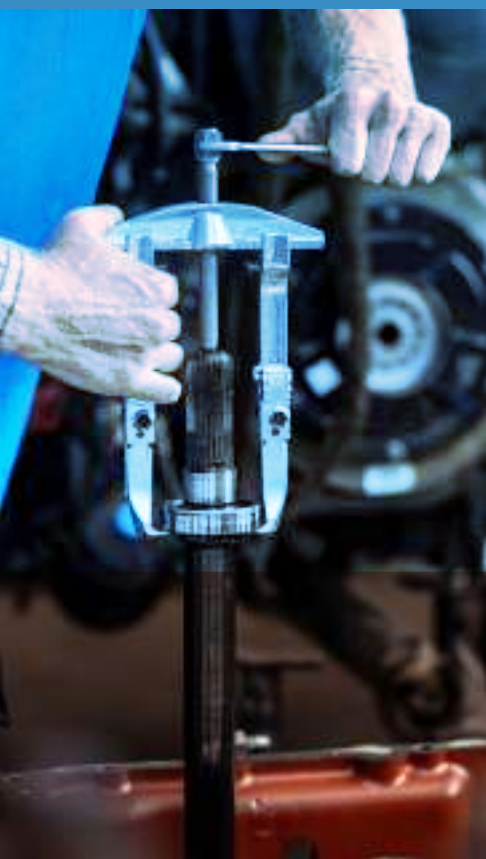

SAFE, PRECISE, POWERFUL

Bolted connections on agricultural machines sometimes require enormous forces when loosening and tightening. Sensitive components in particular require high-quality tools. With GEDORE products, the force is transferred precisely and safely to the fastener.

Torque tools such as the non length dependent and extremely light Dremometer made of aluminum, protect forces and ensure the best working results.

EVERYTHING XL IN THE WORKBENCH WITH TOOLS FOR AGRICULTURAL MACHINERY

A 198-piece tool assortment especially for agricultural machinery, housed in an XL workbench. All tools for service and maintenance work on tractors, combine harvesters, etc. are perfectly organised, stowed away and ready for immediate use at the workplace.

The **GEDORE mobile workbench 1504 XL-S-198** is a top-class mobile work station, equipped with a 198-piece range that is specially tailored to the common work of agricultural and agricultural machinery technicians. In addition to complete 1/4" and 1/2" socket wrench sets, the range also includes pliers, screwdrivers, impact tools and much more. Everything housed in practical foam modules for maximum organization. Four of the seven drawers, each with a load capacity of 40 kg, the lower, extra high heavy-duty drawer even 60 kg, are preloaded with tools in foam inserts. Three more drawers can be used according to your own requirements. For a better overview and easy access to the tools, all drawers have a full extension. When it comes to resilience, the 1504 XL also offers large reserves thanks to the torsion-resistant sheet steel construction. The total carrying capacity is one ton (1000 kg). The mobile

workbench is easily maneuverable even with a load of 750 kg and keeps running smoothly and directional stability. **GEDORE** also offers the 1504 XL-S-306 AGRAR workbench with a 306-piece professional range as extensive equipment.



Agricultural workbench with basic range 1504 XL-S-198 AGRAR

1

WORKBENCH WITH HIGH LOAD CAPACITY

- Wide drawers, large storage space and high load capacity for heavy and large tools

2

CUSTOMIZABLE AND FLEXIBLE

- Can be expanded with a rear wall, additional tools and sets in foam inserts

3

AGRICULTURAL MACHINERY TOOLS

- Tool selection specifically for service and maintenance work on agricultural machinery

4

EXTENSIVE EQUIPMENT

- Socket wrench sets in 1/4" and 1/2", pliers, screwdrivers impact tools and much more in top quality

"The range is perfect for the agricultural sector. I can fill the 3 empty drawers with the tools I already have."

1504 XL-S-198 AGRAR
**WORKBENCH
 WITH BASIC SET**
 198 pieces



€3436,¹³
 + VAT

- > Ideally suited for service and maintenance work on agricultural machinery
- > Metric dimension tools
- > With GEDORE Check-Tool-System: completeness check by 2-colored foam inserts
- > Resistant to oils and fats
- > In workbench no. 1504XL 1411
- > Sheet steel, corrosion-resistant and scratch-resistant powder-coated, GEDORE blue
- > 30 mm thick multiplex beech wood panel, surface additionally protected with linseed oil varnish
- > Large storage space with shelf and door
- > Safety through heel protection for people
- > Central locking with cylinder lock
- > 1 XL drawer (W 1055 x D 400 mm), 6 wide drawers (W 640 x D 400 mm) with full extension, removable
- > Safety lock for each drawer, one-handed operation
- > Ball bearing guide rails
- > Load capacity per drawer 40 kg, lower heavy-duty drawer 60 kg
- > Total load capacity 1000 kg, in mobile operation 750 kg
- > 2 roller-bearing GEDORE high-performance wheels (fixed castors Ø 200 mm)
- > 2 ball-bearing mounted GEDORE smooth-running wheels (swivel castors Ø 125 mm), both with total brakes
- > Even under maximum loads, the GEDORE trapezoidal axle construction ensures: smooth running, maneuverability and directional stability
- > Expandable with rear panel no. R 1504 XL-L
- > Special colors on request

Detailed listing of the range contents on page 134



Code	No.	RAL	Height mm	Width mm	Depth mm	Drawers	Max. load-bearing capacity kg	Number of drawers	Pieces	Weight kg
3434826	1504 XL-S-198 AGRAR	GEDORE blue, RAL 5017	985	1.250	630	1xType XL, H=75mm, extra wide 4xType 1b, H=67mm 1xType 2b, H=137mm 1xType 3b, H=207mm	1000	7	198	157.5

Contents

Mobile workbench 1504 XL 1411 1.25 m wide, Screwdriver bit set 1/4" 620-024, Square handle 1/4" 2098, Socket 20 4 4.5 5 5.5 6 7 8 9 10 11 12 13 14 mm
 Screwdriver bit 1/4" IN 20 4 5 6 8 mm, Screwdriver bit ITX 20 T8 T9 T10 T15 T20 T25, Reversible ratchet 1/4" 2093 U-10
 T-handle 1/4" 2087, Extension 2090-2, Extension 2090-4, Extension 2090-6, Cardan joint 2095
 Socket 1/2" 19 10 11 12 13 14 15 16 17 18 19 20 21 22 23 24 25 26 27 28 29 30 32 33 34 36 mm
 Screwdriver socket 1/2" IN 19 4 5 6 7 8 9 10 12 14 17 19
 Screwdriver bit 1/2" ITX 19 L T20-100 T25-100 T27-100 T30-100 T40-100 T45-100 T50-100 T55-100 T60-100, Reversible ratchet 1/2" 1993 U-10 T
 T-handle 1/2" 1987, Extension 1/2" 1990-3, Extension 1/2" 1990-5, Extension 1/2" 1990-10, Cardan joint 1/2" 1995
 Combination wrench 1 B 6 7 8 9 10 11 12 13 14 15 16 17 18 19 20 21 22 23 24 25 26 27 30 32 34 mm
 Allen key set H 42 EL-88, Offset screwdriver 42 EL 12 14, 3K screwdriver, short form 2153 5.5, 3K screwdriver with impact cap 2154SK 3.5 5.5 6.5 8
 3K screwdriver short form 2161 PH 2, 3K screwdriver with impact cap 2160SK PH 1 PH 2 PH 3 PH 4, 3K screwdriver 2163 TX T10 T15 T20 T25 T30 T40
 Flat butt workshop file 10" 8701 2-10 | 250x25mm, Round workshop file 10" 8722 2-10 | 250x10 mm, Half-round workshop file 10" 8725 2-10 | 250x25 mm
 Water pump pliers 10" 142 10 tsp, Gedore grip pliers 137 10, Combination pliers 8210-160 JC
 Kraft side cutter 8316-200 JC, Multiple pliers 8133-180 JC, Needle nose pliers 8132 AB-200 JC
 Assembly pliers set S 8008, 8 pcs, Pliers wrench 10" 183 10 JC, Locksmith's hammer ROTBAND-PLUS 600 H-600 S
 Locksmith's hammer ROTBAND-PLUS 600 H-1500
 Soft face hammer 248 H-50, Pin Punch 119-2 2 3 4 5 6 7 8 9 10mm
 Grains 100-12, Slotted chisel 104, Cross chisel flat oval 96-175 | 175x17x11mm
 Feeler gauge 702 13 M, Gasket scraper 133 K
 Steel tape measure 4534-8 | 8m, Pocket vernier caliper 710
 Car light test lamp 4610, Wire brush 644, Mounting lever 39
 Solid 906 foam kneeboard, Magnetic lifter 640-1800

1504 XL-S-306 AGRAR

WORKBENCH WITH PROFESSIONAL RANGE

306 pieces



- › Ideally suited for service and maintenance work on agricultural machinery
- › Metric dimension tools
- › With GEDORE Check-Tool-System: completeness check by 2-colored foam inserts
- › Resistant to oils and fats
- › In workbench no. 1504XL 1411
- › Sheet steel, corrosion-resistant and scratch-resistant powder-coated, GEDORE blue
- › 30 mm thick multiplex beech wood panel, surface additionally protected with linseed oil varnish
- › Large storage space with shelf and door
- › Safety through heel protection for people
- › Central locking with cylinder lock
- › 1 XL drawer (W 1055 x D 400 mm), 6 wide drawers (W 640 x D 400 mm) with full extension, removable
- › Safety lock for each drawer, one-handed operation
- › Ball bearing guide rails
- › Load capacity per drawer 40 kg, lower heavy-duty drawer 60 kg
- › Total load capacity 1000 kg, in mobile operation 750 kg
- › 2 roller-bearing GEDORE high-performance wheels (fixed castors Ø 200 mm)
- › 2 ball-bearing mounted GEDORE smooth-running wheels (swivel castors Ø 125 mm), both with total brakes
- › Even under maximum loads, the GEDORE trapezoidal axle construction ensures: smooth running, maneuverability and directional stability
- › Expandable with rear panel no. R 1504 XL-L
- › Special colors on request

Detailed listing of the range contents on page 135

Code	No.	RAL	Height mm	Width mm	Depth mm	Drawers	Max. load-bearing capacity kg	Pieces	Weight kg
3434834	1504 XL-S-306 AGRAR	GEDORE blue, RAL 5017	985	1.250	630	1xType XL, H=75mm, extra wide 7xType 1b, H=67mm 1xType 2b, H=137mm	1000	306	182.9

Contents

Rolling workbench extra wide 1504 XL 1710 | 1.25 m, Screwdriver bit set 1/4" 620-024, Square handle 1/4" 2098
 Socket 20 4 4.5 5 5.5 6 7 8 9 10 11 12 13 14 mm, Screwdriver bit 1/4" IN 20 4 5 6 8 mm, Screwdriver bit ITX 20 T8 T9 T10 T15 T20 T25
 Reversible ratchet 1/4" 2093 U-10, T-handle 1/4" 2087, Extension 2090-2-4-6, Cardan joint 2095
 Socket 1/2" 19 10 11 12 13 14 15 16 17 18 19 20 21 22 23 24 25 26 27 28 29 30 32 33 34 36 mm
 Socket 1/2" D 19 L 10 L 12 L 13 L 14 L 15 L 16 L 17 L 18 L 19 L 21 L 22 L 24 L 27 L 30 L 32 mm
 Screwdriver bit 1/2" IN 19 4 5 6 7 8 9 10 12 14 17 19 mm
 Screwdriver bit 1/2" IN 19 L 6-140 7-140 8-140 9-140 10-140 12-140 14-140 mm
 Screwdriver bit 1/2" ITX 19 L T20-100 T25-100 T27-100 T30-100 T40-100 T45-100 T50-100 T55-100 T60-100
 Socket 1/2" TX 19 E10 E11 E12 E14 E16 E18 E20 E24, Reversible ratchet 1/2" 1993 U-10 T, T-handle 1/2" 1987
 Extension 1/2" 1990-3 -5 -10, Cardan joint 1/2" 1995, Impact socket 1/2" K 19 17 18 19 21 22 23 24 27 30 32
 Power wrench extension 1/2" KB 1990-5, Adapter set S 2032-05, 5 pieces, Check tool inlay with assortment 2005 CT4-7 XL
 Combination wrench 1 B 6 7 8 9 10 11 12 13 14 15 16 17 18 19 20 21 22 23 24 25 26 27 30 32 34 mm
 Open-end wrench with ring ratchet 7 R 10 11 12 13 14 15 16 17 18 19 21 22 24 mm, Starter block wrench 304 13x15 14x17 19x22 mm
 Double box wrench open 400 9x11 10x12 13x15 14x17 19x22 24x27, Allen key set H 42 EL-88, Offset screwdriver 42 EL 12 14
 Offset screwdriver set PH 42-88, 8 pieces, Angle screwdriver 42 7 9 12 14 17 19 22 mm, 3K screwdriver, short form 2153 5.5
 3K screwdriver with impact cap 2154SK 3.5 5.5 6.5 8, 3K screwdriver short form 2161 PH 2, 3K screwdriver with impact cap 2160SK PH 1 PH 2 PH 3 PH 4
 3K screwdriver 2163 TX T10 T15 T20 T25 T30 T40, Socket wrench 2133 6 7 8 10 11 12 13 mm, Flat blunt workshop file 8701 2-10 | 10"
 Round workshop file 8722 2-10 | 10", Half-round workshop file 8725 2-10 | 10", Water pump pliers 142 10 TL | 10", Gedore grip pliers 137 10
 Combination pliers 8210-160 JC, Kraft side cutter 8316-200 JC, Multiple pliers 8133-180 JC, Needle nose pliers 8132 AB-200 JC
 Assembly pliers set S 8008, 8 pieces, Pliers wrench 183 10 JC | 10", Locksmith's hammer ROTBAND-PLUS 600 H-600
 Locksmith's hammer ROTBAND-PLUS 600 H-1500, Soft face hammer 248 H-50, Pin punch 119-2 2 3 4 5 6 7 8 9 10, Grains 100-12, Slotted chisel 104
 Cross chisel flat oval 96-175 | 175x17x11 mm, Feeler gauge 702 13 M, Gasket scraper 133 K, Steel tape measure 4534-8 | 8m, Pocket vernier caliper 710
 Car light test lamp 4610, Wire brush 644, Mounting lever 39, Solid 906 foam kneeboard, Magnetic lifter 640-1800

APPRECIATED WORK

133 K GASKET SCRAPER

› With blue plastic handle



€17,²²
+ VAT

Code	No.	Blade width	Total length mm	Weight kg
6535190	133 K	22,5	240	0.154

905 CREEPER

- › Made of PP (polypropylene) - resistant to oils, greases and brake fluid
- › Fatigue-free working, with head/neck cushion for maximum comfort
- › Bucket moulding gives additional hold and allows maximum freedom of movement
- › Load capacity 130 kg



€72,²⁶
+ VAT

Code	No.	Length mm	Height mm	Width mm	Weight kg
1823698	905	1.000	120	480	5.5

906
KNEELING BOARD

- > Made of solid foam, blue/black
- > With recessed grip



€11,76
+ VAT

Code	No.	Length mm	Height mm	Width mm	Weight kg
1942948	906	450	30	210	0.11

36 2-200
STRAP WRENCH

- > With strong, non-slip fabric strap (E-36), extra wide = 25 mm



€43,35
+ VAT

Code	No.	for Ø mm	for Ø inch	Total length mm	Tape width mm	Weight kg
6327400	36 2-200	200	8"	285	25	0.578

SB 6952-00
RESCUE KNIFE

- > For assured cutting, severing and dissecting a wide range of materials
- > High-grade, universal jack knife with extra belt cutter and glass shatterer
- > Tempered blade with partial serration



€18,06
+ VAT

Code	No.	Blade length mm	Total length mm	Weight kg
3100464	SB 6952-00	85	200	0.146

8551 S-005
BOLT EXTRACTOR SET
 5 pieces



- > For removing broken screws, bolts and tube ends
- > Minimum extraction force torque thanks to the new cross-sectional geometry
- > Reduced drilling depth thanks to an optimised thread length
- > In plastic box

€19,⁹¹
+ VAT

Code	No.	Contents	Width mm	Height mm	Depth mm	Pieces	Weight kg
2659336	8551 S-005	8551 S screw extractor M3-M6 M6-M8 M8-M11 M11-M14 M14-M18	230	15	52	5	0.125

640-1800
MAGNETIC LIFTER

€36,¹³
+ VAT

- > With flexible shaft and plastic handle
- > For picking up and holding small magnetic parts
- > Easy handling due to flexible shaft



Code	No.	Total length mm	Magnet diameter	Magnetic lifting force g	Weight kg
6531280	640-1800	520	12,0	1.800	0.23

120
WRECKING BAR

- > Made of special steel

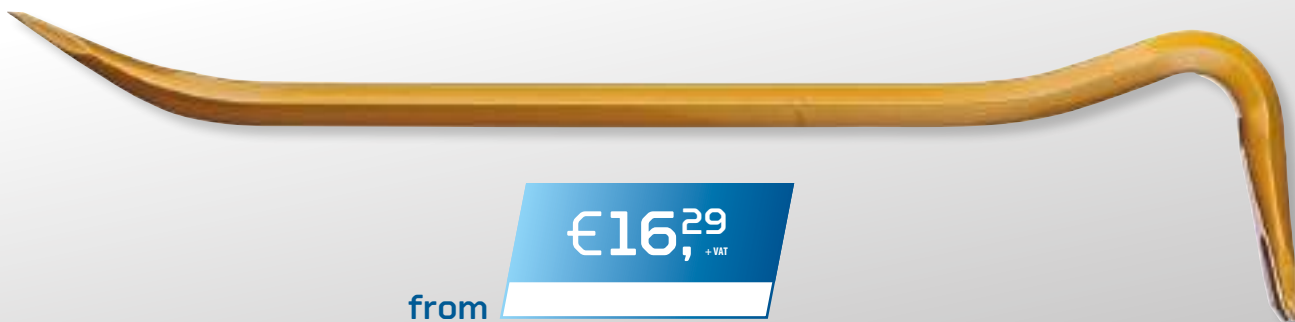

€16,²⁹
+ VAT
 from

Code	No.	Total length mm	Hexagonal	Weight kg	excl. VAT
8769410	120-500	500	18 mm	1.15	16,29
8769920	120-1000	1.000	18 mm	2.175	20,83

OX 644 H-1255
**HATCHET
 SPLIT-QUICK
 ROTBAND-PLUS**

€67,⁸¹
 + VAT



- › Optimum splitting results, less force required due to wedge-shaped blade
- › With handle join ROTBAND-PLUS
- › With high-quality hickory wood handle in knob form



Code	No.	Test seal (OCH)	Weight of head g	Blade width mm	Handle length	Weight kg
1852728	OX 644 H-1255	KWF STD GS	1250 g	100,0	500	1.95

OX 648 H-1257
SPALT-FIX[®]-AXT ROTBAND-PLUS

€83,⁹⁵
 + VAT



- › Optimum splitting results, less force required due to wedge-shaped blade
- › With handle join ROTBAND-PLUS
- › With high-quality hickory wood handle in knob form



Code	No.	Test seal (OCH)	Weight of head g	Blade width mm	Handle length	Weight kg
1962396	OX 648 H-1257	KWF STD GS	1250 g	100,0	700	2.15

OX 620 H-1257
**UNIVERSAL FORESTRY AXE
 ROTBAND-PLUS**

Rhineland pattern

€87,³⁹
 + VAT



- › Indispensable in wood-working and gardening
- › With patented handle join ROTBAND-PLUS: Handle sleeve, tapered collar, fixing plate and wood screw bond the hammer head and the handle into one unit and ensure an optimum in safety
- › The long handle sleeve made of steel protects the handle from damage when the hammer misses its target. This guarantees a long service life
- › Fine polished axe head with blade-protection
- › With high quality hickory wood handle in cow foot shape
- › The spare handle is delivered complete with protective sleeve, tapered collar, fixing plate and wood screw



Code	No.	Test seal (OCH)	Weight of head g	Blade width mm	Handle length	Weight kg
1879812	OX 620 H-1257	KWF STD GS	1250 g	120,0	700	2.1

OX 635 H-3009

WOOD SPLITTING HAMMER PROFESSIONAL BIG OX®

- > With handle join ROTBAND-PLUS
- > Forged hammer head with turning nose and extra large striking face, e.g. for driving wedges
- > With high quality hickory wood handle in knob form and blade protection



€90,⁶⁷ + VAT



Code	No.	Test seal (OCH)	Weight of head g	Blade width mm	Handle length	Weight kg
1707663	OX 635 H-3009	KWF PRO GS	3000 g	70,0	900	4.2

OX 31 - OX 34

PLASTIC FELLING WEDGE

- > For felling only, not suitable for splitting
- > Optimum wedge effect even in frozen wood
- > Made of high-quality, recycled polyamide polyamide plastic
- > Extremely impact-resistant and therefore ideal for felling, even in extreme cold



from

€10,⁸³ + VAT



Code	No.	Description	Test seal (OCH)	Lifting height (max.)	Length mm	Width mm	Weight kg	excl. VAT
1592041	OX 32-0100	Plastic felling wedge, YUKON type	KWF PRO	25	180	65	0.16	10,83
1592068	OX 31-0300	Plastic felling wedge, ALASKA type	KWF PRO	30	230	70	0.26	10,83
1592076	OX 34-0400	Plastic felling wedge, LABRADOR type	KWF PRO	40	240	73	0.41	15,37

The individual components at a glance

WSL-M-TS-172



Spanner assortment in CT insert



Socket assortment in CT insert



Tool assortment in CT insert



8550-024

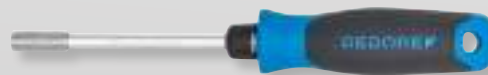

2675



Assortment
WSL-M-TS-172

No.
Spanner assortment
in CT insert

Socket assortment
in CT insert

Tool assortment
in CT insert

8550-024
2675

Contents

Combination spanner No. 1 B, 8 10 11 12 13 14 15 16 17 18 19 21 22 24 27 30 32 mm,
fitter's hammer No. 4 E-500, 500 g

Socket No. C19, 8 10 11 12 13 14 15 16 17 18 19 20 21 22 24 27 30 32 mm
1/2" Screwdriver bit hexagonal No. IN19, 5 6 7 8 9 10 12 14 17 19 mm
1/2" Reversible ratchet No. 1993 U-10 T
1/2" extension No. 1990, 75 125 250 mm
1/2" extension No.1990 M with holding magnet
No. 666-U-20 Bit socket box with ratchet 1/4" 35 pcs.
No. 666-042 Torsion bit set

No. H 42-10 Hex key L-wrenches 1.3 1.5 2 2.5 3 4 5 6 8 10 mm
No. 2150 3C-Screwdriver 4 5 5 6 8 mm
No. 2160 3C-Screwdriver PH 1 2
No. 142 10 TL Universal pliers 10"
No. 8133-200 JC Multiple pliers 200 mm
No. 8316-180 JC Power side cutters 180 mm
No. 8250-180 JC Power combination pliers 180 mm
No. 4615 3 Voltage tester slot 220-250 V

Twist drill set Ø 1 1,5 2 2,5 3 3,5 4 4,5 5 5,6 6,5 7 7,5 8 8,5 9 9,5 10 10,5 mm
1/4" ratchet screwdriver SilentGEAR No. 2675 with bit holder

pieces
172

The individual components at a glance

TTB-TS-173



Spanner assortment in CT insert



Tool assortment in CT insert



Assortment
TTB-TS-173

No.
Spanner assortment
in CT insert

Contents

- 1/2" reversible ratchet No. 1993 U-20
- 1/2" extension No. 1990-3 -5 -10
- 1/2" Socket No. D 19, 10 12 13 15 16 17 18 19 22 24 27 30 32 mm
- 1/2" Screwdriver bit hexagonal No. IN 19, 5 6 7 8 9 10 12 14 17 19 mm
- 1/2" extension with holding magnet No 1990 M
- Combination spanner No. 1 B, 8 10 11 12 13 14 15 16 17 18 19 21 22 24 27 30 32 mm
- Bit socket spanner box with ratchet 1/4" No. 666-U-20

Tool assortment
in CT insert

- Offset screwdriver set No. H 42-10, 10 pieces
- Torsion bit set No. 666-042, 42 pieces,
- 3C-Screwdriver slot No. 2150, 4 5.5 6.5 8 mm,
- 3C screwdriver cross recess No. 2160 PH, PH 1 2,
- Universal pliers No. 142 10TL
- Multi-purpose pliers No. 8133-200 JC
- Side cutters No. 8314-180 JC,
- Test screwdriver No. 4615 3
- Locksmith's hammer No. 4 E-500,
- Twist drill set No. 8550-024, 24 pieces
- Pin punch set No. 316 D, 6 pieces

pieces
173

The individual components at a glance

1504 XL-S-198 AGRAR

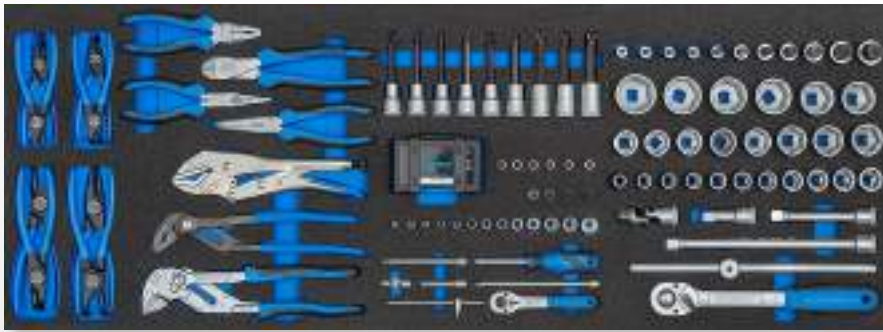

1504 XL CT6-U10-183



2005 CT4-2153-63



2005 CT4-119-600



2005 CT4-1B



906



600 H-1500



39

Assortment	No.	Contents	pieces
1504 XL-S-198 AGRAR	1504 XL CT6-U10-183	1/4" Screwdriver bit set 620-024, 1/4" Square handle 2098, 1/4" Socket hex 20 4 4,5 5,5 6 7 8 9 10 11 12 13 14, 1/4" screwdriver bit IN 20 4 5 6 8, 1/4" screwdriver bit ITX 20 T8 T9 T10 T15 T20 T25, 2093 U-10 reversible ratchet, 1/4" cross handle 2087, 1/4" extension 2090-2-4-6, 1/4" universal joint 2095, 1/2" socket 19 10 11 12 13 14 15 16 17 18 19 20 21 22 23 24 25 26 27 28 29 30 32 33 34 36, 1/2" screwdriver bit IN 19 4 5 6 7 8 9 10 12 14 17 19, 1/2" screwdriver bit ITX 19 L T20-100 T25-100 T27-100 T30-100 T40-100 T45-100 T50-100 T55-100 T60-100, 1993 U-10 T reversible ratchet, 1/2" cross handle 1987, extension 1990-3-5-10, universal joint 1995, water pump pliers 10" 142 10 TL, Gedore grip pliers 137 10, combination pliers 8210-160 JC, Power side cutters 8316-200 JC, Multi nose pliers 8133-180 JC, Flat round nose pliers 8132 AB-200 JC, Assembly pliers set 8 pcs S 8008, Pliers spanner 10" 183 10 JC	198
	2005 CT4-2153-63	H 42 EL-88 Offset screwdriver set, Offset screwdriver 42 EL 12 14, 3C-Screwdriver 2153 5.5, 3C-Screwdriver with striking cap 2154SK 3.5 5.5 6.5 8, 3C-Screwdriver 2161 PH 2, 3C-Screwdriver with striking cap 2160SK PH 1 2 3 4, 3C-Screwdriver 2163 TX T10 T15 T20 T25 T30 T40, steel tape measure 8 m 4534-8, car light test lamp 4610, magnetic lifter 640-1800, feeler gauge 702 13 M	
	2005 CT4-119-600	Metalworker's hammer ROTBAND-PLUS 600 H-600, soft-face hammer 248 H-50, pin punch 119-2-3-4-5-6-7-8-9-10, centre punch 100-12, slotted chisel 104, cross chisel 96-175, sealing scraper 133 K, pocket caliper 710, wire brush 644, Flat blunt workshop file 10" 8701 2-10, Round workshop file 10" 8722 2-10, Half round workshop file 10" 8725 2-10	
	2005 CT4-1B	Combination spanner 1 B 6 7 8 9 10 11 12 13 14 15 16 17 18 19 20 21 22 23 24 25 26 27 30 32 34	
	600 H-1500	Metalworker's hammer ROTBAND-PLUS	
	39	Mounting lever	
	906	Solid foam kneeboard	

The individual components at a glance

1504 XL-S-306 AGRAR



1504 XL CT6-U10-183



906

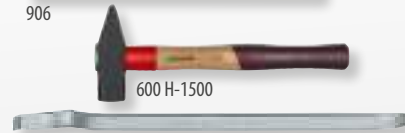

39



2005 CT4-1B



2005 CT4-2153-63



2005 CT4-119-600



2005 CT4-D19L-2133



2005 CT4-7R-400



2005 CT4-7 XL

Assortment	No.	Contents	pieces
1504 XL-S-306 AGRAR	1504 XL CT6-U10-183	1/4" Screwdriver bit set 620-024, 1/4" Square handle 2098, 1/4" Socket hex 20 4 4, 5 5, 5 6 7 8 9 10 11 12 13 14, 1/4" screwdriver bit IN 20 4 5 6 8, 1/4" screwdriver bit ITX 20 T8 T9 T10 T15 T20 T25, 2093 U-10 reversible ratchet, 1/4" cross handle 2087, 1/4" extension 2090-2-4-6, 1/4" universal joint 2095, 1/2" socket 19 10 11 12 13 14 15 16 17 18 19 20 21 22 23 24 25 26 27 28 29 30 32 33 34 36, 1/2" screwdriver bit IN 19 4 5 6 7 8 9 10 12 14 17 19, 1/2" screwdriver bit ITX 19 L T20-100 T25-100 T27-100 T30-100 T40-100 T45-100 T50-100 T55-100 T60-100, 1993 U-10 T reversible ratchet, 1/2" cross handle 1987, extension 1990-3-5-10, universal joint 1995, water pump pliers 10" 142 10 TL, Gedore grip pliers 137 10, combination pliers 8210-160 JC, Power side cutters 8316-200 JC, Multi nose pliers 8133-180 JC, Flat round nose pliers 8132 AB-200 JC, Assembly pliers set 8 pcs S 8008, Pliers spanner 10" 183 10 JC	306
	2005 CT4-2153-63	H 42 EL-88 Offset screwdriver set, Offset screwdriver 42 EL 12 14, 3C-Screwdriver 2153 5.5, 3C-Screwdriver with striking cap 2154SK 3.5 5.5 6.5 8, 3C-Screwdriver 2161 PH 2, 3C-Screwdriver with striking cap 2160SK PH 1 2 3 4, 3C-Screwdriver 2163 TX T10 T15 T20 T25 T30 T40, steel tape measure 8 m 4534-8, car light test lamp 4610, magnetic lifter 640-1800, feeler gauge 702 13 M	
	2005 CT4-119-600	Metalworker's hammer ROTBAND-PLUS 600 H-600, soft-face hammer 248 H-50, pin punch 119-2-3-4-5-6-7-8-9-10, centre punch 100-12, slotted chisel 104, cross chisel 96-175, sealing scraper 133 K, pocket caliper 710, wire brush 644, Flat blunt workshop file 10" 8701 2-10, Round workshop file 10" 8722 2-10, Half round workshop file 10" 8725 2-10	
	2005 CT4-1B	Combination spanner 1 B 6 7 8 9 10 11 12 13 14 15 16 17 18 19 20 21 22 23 24 25 26 27 30 32 34	
	2005 CT4-D19L-2133	1/2" Socket 19 10 11 12 13 14 15 16 17 18 19 20 21 22 23 24 25 26 27 28 29 30 32 33 34 36, 1/2" Socket D 19 L 10 12 13 14 15 16 17 18 19 21 22 24 27 30 32, 1/2" Screwdriver bit IN 19 4 5 6 7 8 9 10 12 14 17 19, 1/2" Screwdriver bit socket IN 19 L 6-140 7-140 8-140 9-140 10-140 12-140 14-140, 1/2" Screwdriver bit socket ITX 19 L T20-100 T25-100 T27-100 T30-100 T40-100 T45-100 T50-100 T55-100 T60-100, 1/2" Socket TX 19 E10 E11 E12 E14 E16 E18 E20 E24, 1993 U-10 T reversible ratchet, 1/2" cross handle 1987, extension 1990-3-5-10, universal joint 1995, 1/2" power wrench socket K 19 17 18 19 21 22 23 24 27 30 32, 1/2" power wrench extension KB 1990-5, Adapter set 5-piece S 2032-05, Socket spanner 2133 6 7 8 10 11 12 13	
	2005 CT4-7R-400	Combination ratchet spanner 7 R 10 11 12 13 14 15 16 17 18 19 21 22 24, Starter block spanner 304 13x15 14x17 19x22, Double ended ring spanner open 400 9x11 10x12 13x15 14x17 19x22 24x27, Offset screwdriver set PH 42-88 8 pieces, Offset screwdriver 42 7 9 12 14 17 19 22	
	2005 CT4-7 XL	Combination spanner 7 XL 10 11 12 13 14 15 16 17 18 19 21 22 24 27 30 32 36 41	
	600 H-1500	Metalworker's hammer ROTBAND-PLUS	
	39	Mounting lever	
	906	Solid foam kneeboard	



TOOLS FOR LIFE

GEDORE Werkzeugfabrik GmbH & Co. KG

Remscheider Straße 149
42899 Remscheid · GERMANY
Tel. + 49 (0) 21 91- 596 - 0
Fax + 49 (0) 21 91- 596 - 230
info@gedore.com
www.gedore.com

Vertrieb Deutschland
Tel. + 49 (0) 21 91- 596 - 900
Fax + 49 (0) 21 91- 596 - 999

GEDORE Automotive GmbH

Breslauer Straße 41
78166 Donaueschingen · GERMANY
Tel. +49 771 83223-0
Fax +49 771 83223-90

GEDORE Torque Solutions GmbH

Bertha-Benz-Straße 12
71665 Vaihingen/Enz · GERMANY
T +49 7042 9441-0
F +49 7042 9441-41
torque-solutions@gedore.com

GEDORE AUSTRIA GmbH

Gedore-Str. 1
8190 Birkfeld / Stmk. · AUSTRIA
Tel. +43 (0) 3174 / 363 64 00
Fax +43 (0) 3174 / 363 83 20
sales.austria@gedore.com
www.gedore.at

GEDORE Tools S.A. (Pty) Ltd.

103 Qashana Khuzwayo (Shepstone) Road,
New Germany, 3610 - South Africa
PO Box 68, New Germany, 3620
SOUTH AFRICA
Tel. +27 (0) 31 / 705 3587
Fax +27 (0) 31 / 705 32770
esales@gedore.co.za
www.gedore.co.za

GEDORE IBÉRICA S.L.

c/Arangutxi 12, Poligono Industrial de Júndiz
01015 Vitoria Alava · SPAIN
Tel. +34-945-29 22 62
Fax +34-945-29 21 99
gedore@gedore.es
www.gedore.es

GEDORE Torque Ltd

(Formerly Gedore UK)
Tannery Lane, Gosden Common
Bramley, Guildford
Surrey
GU5 0AJ · UNITED KINGDOM
Tel. +44 (0) 1756 / 70 67 00
sales@gedoreuk.com
www.gedoreuk.com

GEDORE France SARL

Parc d'activités des Béthunes - La Mare II
10, avenue du Fief - Bât. 12
BP 79144 Saint-Ouen-l'Aumône
F-95074 Cergy Pontoise Cedex · FRANCE
Tél. +33 (0)1 34 40 16 60
Fax +33 (0)1 34 40 16 61
jadore@gedore.fr
www.gedore.fr

GEDORE TECHNAG B.V.

Flemingweg 7, 2408 AV
Alphen aan den Rijn · NETHERLANDS
Tel. +31 (0) 172 / 42 73 50
Fax +31 (0) 172 / 42 73 60
info@gedore.nl
www.gedore.nl

GEDORE (INDIA) Private Limited

148, Sector 3, IMT Manesar
Gurgaon – 122051
Haryana · INDIA
Tel. +91 (0) 124 22910 – 65/66/67
Fax +91 124 2341067
sales@gedoreindia.com
www.gedore.in

GEDORE POLSKA Sp. z o.o.

ul. Żwirki i Wigury 56a
43-190 Mikołów · POLAND
Tel. +48 (0) 32 / 738-40 10
Fax +48 (0) 32 / 738-40 20
gedore@gedore.pl
www.gedore.pl

Ferramentas GEDORE do Brasil S.A.

Rua Vicentina Maria Fidélis,
275 Bairro Vicentina
São Leopoldo - RS | 93025-340 · BRAZIL
Tel. +55 51- 3589 9200
Fax + 55 51- 3589 9222
export@gedore.com.br
www.gedore.com.br

GEDORE TOOLS INC

4055 Faber Pl Dr
North Charleston SC, 29405 · USA
Phone: +1 (843) 225 5015
Fax: +1 (843) 300 0315
info@gedoretools.com
www.gedoretools.com

GEDORE Tool Trading (Shanghai) Co., Ltd.

1/F, Block 2, 1358 Pingan Road,
Minhang, Shanghai · CHINA 201109
Tel. +86-21-3388 7258
Fax +86-21-3388 7259
Service Hotline: 400 880 1858
info@gedore.cn
www.gedore.cn

Your dealer:

Brands of the GEDORE Group

gedore.com · ochsenkopf.com

MAGIC 2023 TOOL PROMOTION valid
from 01/03/2023 until 31/12/2023.
While stocks last.

*Special net prices per pc./set, plus VAT. Delivery without decoration.
Technical specifications subject to modifications. No liability for printing errors.
Prices exclude VAT / for resellers only. Please ask your local dealer.

gedore.com